

# TECHNICAL INFORMATION



New Tool

Models No. ▶ 6832

Description ▶ Auto Feed Screwdriver

## CONCEPTION AND MAIN APPLICATIONS

This tool accepts screw strips  $\phi 4\text{mm}$  (5/32") x25mm(1") to 57mm(2-1/4"). Use of extension handle (optional accessories) allows you to drive screws into floor while standing.

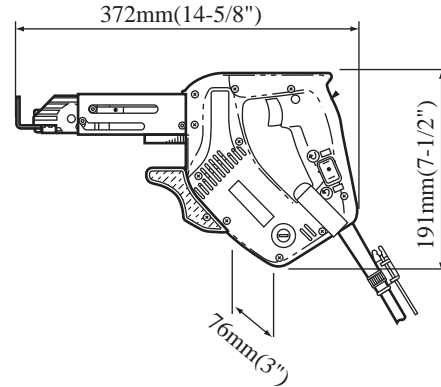

### ► Specifications

Voltage (V)	Current (A)	Cycle (Hz)	Continuous Rating (W)		Max. Output(W)
			Input	Output	
100	5.0	50/60	470	220	400
115	4.3	50/60	470	220	400
200	2.5	50/60	470	220	400
220	2.3	50/60	470	220	400
230	2.2	50/60	470	220	400
240	2.1	50/60	470	220	400

#### Capacities

Screw strip	$\phi 4\text{mm}$ (5/32")x25mm (1")-57mm(2-1/4")
No Load Speed	0-2,800 R/min.
Net Weight	2.0Kg (4.4 lbs)

### ► Standard equipment

Hex wrench, Wrench holder, Phillips bit 2-132 (2 pcs.), Stopper plate for screws 25 mm (1") to 41 mm (1-5/8") long, Hex socket head bolt M4x8, Plastic carrying case

### ► Optional accessories

Phillips bit 2-132 (5 pcs. in set), Extension handle