

# T ECHNICAL INFORMATION



New Tool

**Models No.** ▶ 6833

**Description** ▶ Auto Feed Screwdriver

## CONCEPTION AND MAIN APPLICATIONS

These new auto feed screwdrivers are developed as improved models of the current models 6830 and 6832.

Their main new features are; -

1. Improved design of case enabling to drive screws at the edge only 15mm away from the wall board.
2. Tool-less System for depth adjustment of screws and taking off the casing.
3. Reverseing system of drywall screw strip.
4. More excellent tool balance for easier operation.

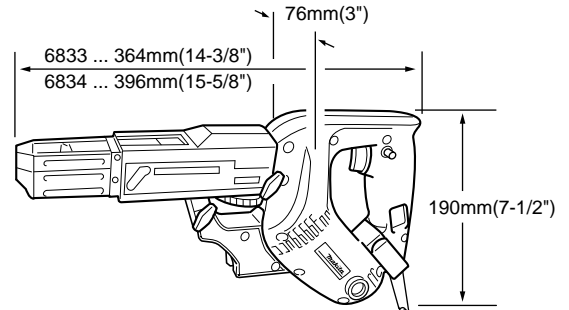

Model 6833 can accept 25 to 41mm screws.

Model 6834 for 25 to 57mm screws.

### ► Specifications

Voltage(V)	Current(A)	Cycle(Hz)	Continuous Rating(W)		Max.Output(W)
			Input	Output	
100	5.0	50/60	470	220	400
120	4.3	50/60	470	220	400
200	2.5	50/60	470	220	400
220	2.3	50/60	470	220	400
230	2.2	50/60	470	220	400
240	2.1	50/60	470	220	400

Model No.	6833	6834
No Load Speed (rpm)	4700	2800
Capacities screw strip	ø4 x 25~41mm (5/32" x 1"~1-5/8")	ø4 x 25~57mm (5/32" x 1"~2-1/4")
Net Weigh (kg)	1.9(4.21bs)	1.9(4.21bs)

### ► Standard equipment

Phillips bit 2-132(2 pcs.) for 6833

Phillips Bit 2-146(2 pcs.) for 6834

Plastic Carrying Case

### ► Optional accessories

Phillips Bit 2-132(5 pcs.) for 6833

Phillips Bit 2-146(2 pcs.) for 6834

Extensions Handle set

The Standard equipment for the tools shown may differ from country to country.

## ► Repair

### 1. [Assembly/Disassembly of Spiral bevel gear]

In Spiral bevel gear, Armature shaft is inserted by pressure. First, knock-down and assemble it by Arbor press. When inserting Shaft, put it by pressure so that the end face of Spiral gear 15 stick to the counter edge of Armature shaft. (see right figure)

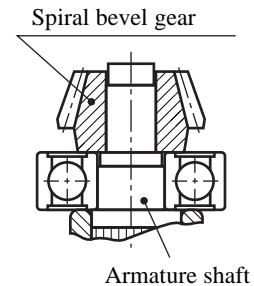

### 2. [Attachment of Clutch part]

(1) As the illustrations below, attach Compression spring 5 to Flange head pin 8 and install it into Spindle. Once insert it deeply, and check if Compression spring 5 has been put into the spindle side.

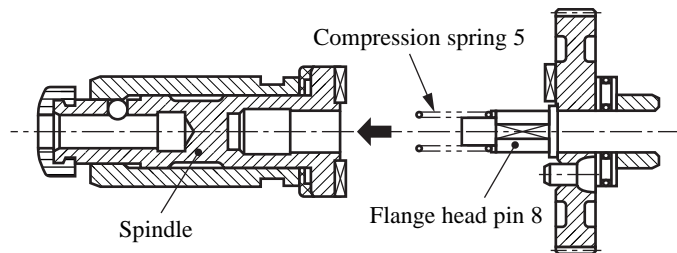

(2) After assembly in the condition of the right illustration, put it into housing.

(Note)

In attaching, be sure to make the chamfering side outside.

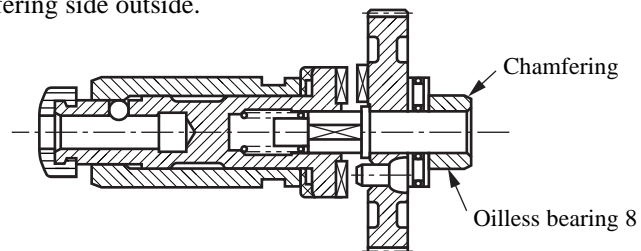

### 3. [Notes in assembly of screw feeding mechanism]

- (1) On rotation part or rubbing face of this part, if you apply grease, lubrication oil, or anti-rust oil, dusts or particles will attach there, which may cause the operation disorder. So, please do not apply any kind of oil.
- (2) As for attachment of Wheel and Spar gear 16, match Wheel nail with Arc part of Spar gear 16 and install it. After installation, check if it rotates by pressing with a finger the center of Wheel.

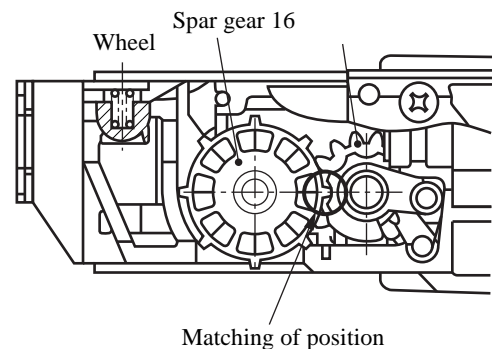

## ► Wiring diagram

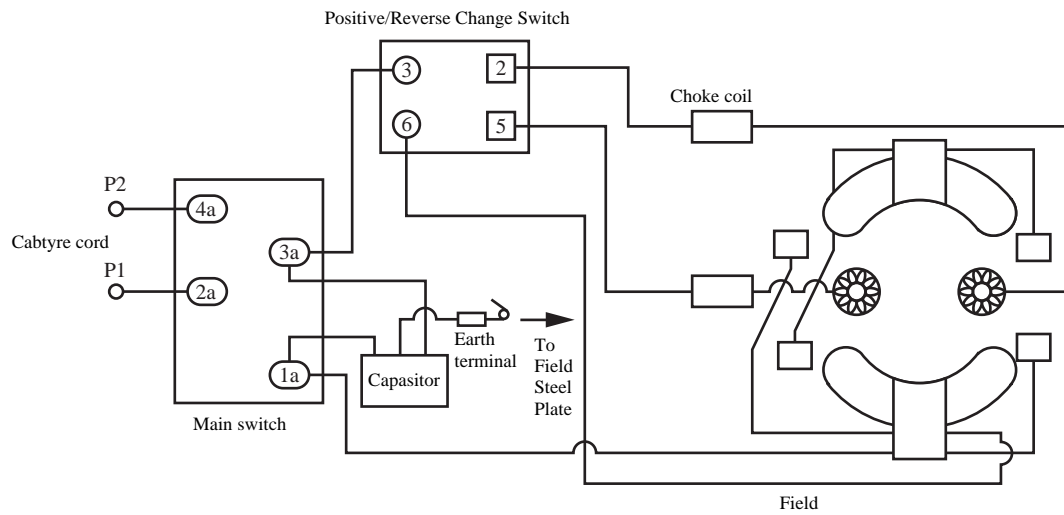

[Note] \* There are some areas where Condenser is not used or where 2-foot condenser (without earth line) is used.  
\* In some area Choke coil is not used.