

TECHNICAL INFORMATION



PRODUCT

P 1/16

Model No. ▶ 6842, 6843, 6844

Description ▶ Auto Feed Screwdriver

CONCEPT AND MAIN APPLICATIONS

Models 6842, 6843 and 6844 have been developed as the successor models of 6833 series models. These models feature more reliable casing attachment with the following benefits:

- Rigid aluminum casing
- Stopper base with anti-tilt device for preventing screws from swaying
- Rubber cap securely fixed to stopper base
- Dust-proof construction for smooth sliding action

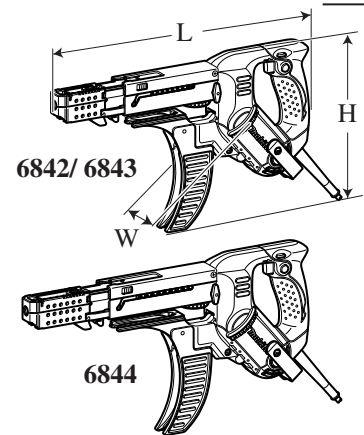

6842 series also includes Auto feed screwdriver with coil magazine available as Model 6845.

Dimensions: mm (")		
	6842/ 6843	6844
Length (L)	400 (15-3/4)	440 (17-1/4)
Width (W)	75 (2-15/16)	
Height (H)	243 (9-9/16)	

► Specification

6842/ 6843/ 6844

Voltage (V)	Current (A)	Cycle (Hz)	Continuous Rating (W)		Max. Output (W)
			Input	Output	
110	4.5	50/60	470	190	400
120	4.3	50/60	---	190	400
220	2.3	50/60	470	190	400
230	2.2	50/60	470	190	400
240	2.1	50/60	470	190	400

Specification	Model	6842	6843	6844
No load speed: min.-1 = rpm		4,700	6,000	3,000
Driver bit: mm (")	Shank	6.35 (1/4) Hex		
	Overall length*	162 (6-3/8) or 157 (6-3/16)		182 (7-1/8) or 177 (7)
Capacities: mm (") [collated drywall screw]	Diameter	4 (5/32)		
	Overall length	25 to 55 (1 to 2-3/16)		45 to 75 (1-3/4 to 2-15/16)
Reverse switch		Yes		
Protection against electric shock		Double insulation		
Power supply cord: m (ft)		Europe: 4.0 (13.1), Other countries: 2.5 (8.2)		
Net weight: kg (lbs)		2.0 (4.4)		2.1 (4.6)

*Overall length of driver bit may differ by country.

► Standard equipment

6842/ 6843

Phillips bit 2-162 or 2-157 3
 Belt clip 1
 Thumb screw (for fixing Belt clip) 1
 Plastic carrying case 1

6844

Phillips bit 2-182 or 2-177 3
 Belt clip 1
 Thumb screw (for fixing Belt clip) 1
 Plastic carrying case 1

Note: The standard equipment for the tool shown above may differ by country.

► Optional accessories

Phillips bit 2-162 or 2-157 (for **6842/ 6843**) Extension handle
 Square bit 2-162 or 2-157 (for **6842/ 6843**) Casing attachment
 Phillips bit 2-182 or 2-177 (for **6844**) Plastic carrying case
 Square bit 2-182 or 2-177 (for **6844**)

► Repair

CAUTION: Unplug the machine and remove the driver bit from the machine for safety before repair/ maintenance in accordance with the instruction manual!

[1] NECESSARY REPAIRING TOOLS

Code No.	Description	Use for
1R032	Bearing setting plate 8.2	Removing Pin 2 from Guide box complete
1R266	Spring pin extractor 2	
1R269	Bearing extractor	Removing Spiral bevel gear 15
1R291	Retaining ring S and R pliers	Removing Casing cover and Insulation sleeve

[2] LUBRICATION

Apply Makita grease FA.No.2 to the following portions designated with the black triangle to protect parts and product from unusual abrasion.

Item No.	Description	Portion to lubricate
④9	Steel ball 3.5	Whole surface
⑤0	Spindle B	(a) Drum portion that contacts Plane bearing 14 (b) Cam portion that contacts ⑤2 Clutch cam C
⑤2	Clutch cam C	Each depressed portion for Steel ball 4
⑥0	Spiral bevel gear 22	Teeth portion that engages Spiral bevel gear 15
⑥1	Helical gear 13 for 6842 Helical gear 16 for 6843 Helical gear 9 for 6844	Teeth portion that engages Helical gear 57 Teeth portion that engages Helical gear 53 Teeth portion that engages Helical gear 60

Fig. 1

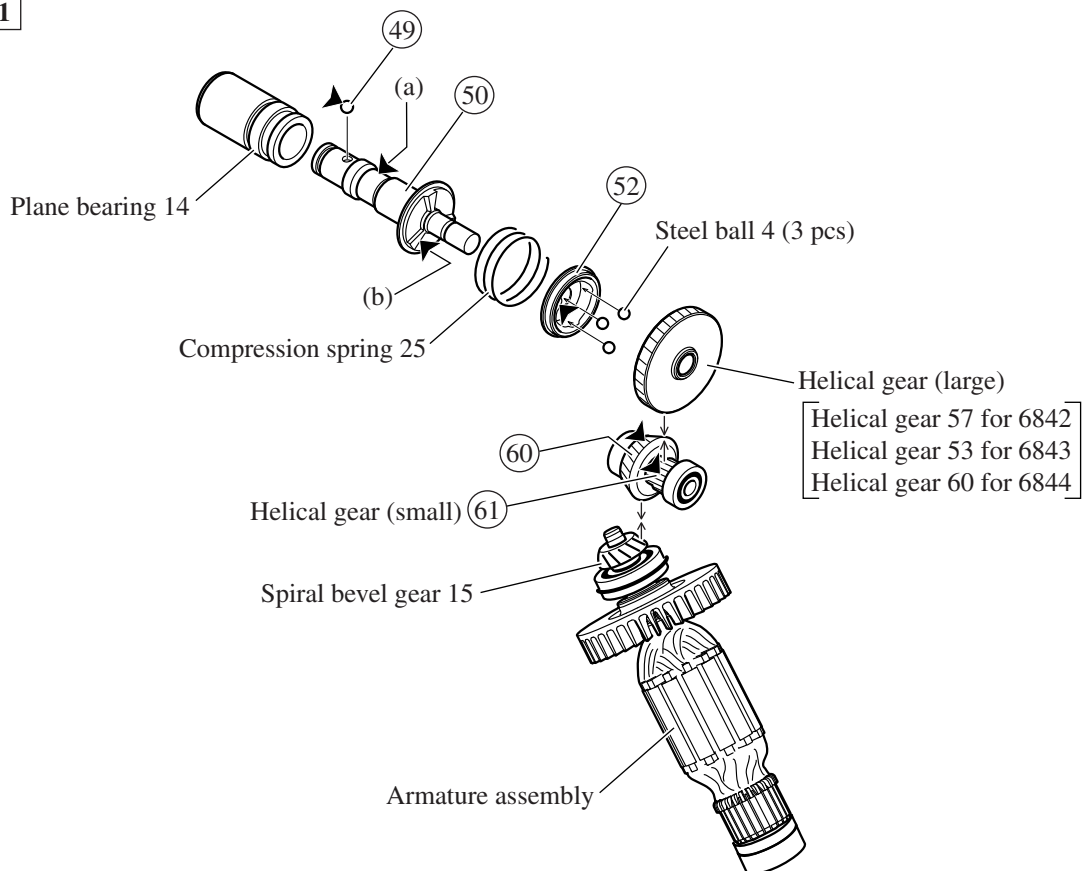

► **Repair**

[3] DISASSEMBLY/ASSEMBLY

[3] -1. Casing Assembly and Feeder Box Assembly

DISASSEMBLING

Disassemble by taking the steps described in Fig. 2 to Fig 17.

Fig. 2

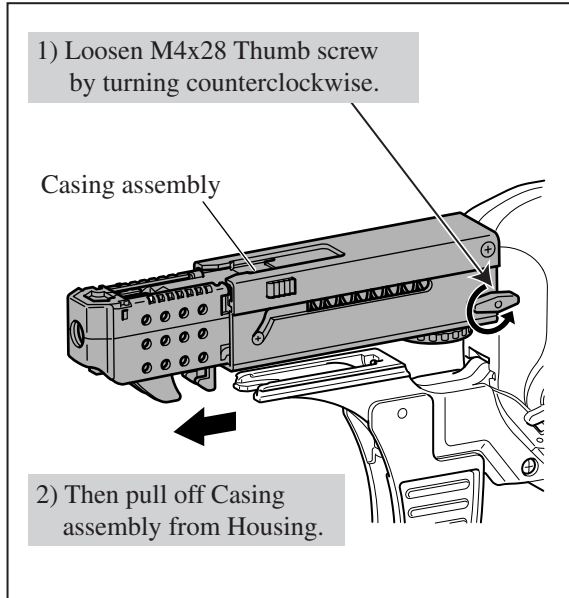

Fig. 3

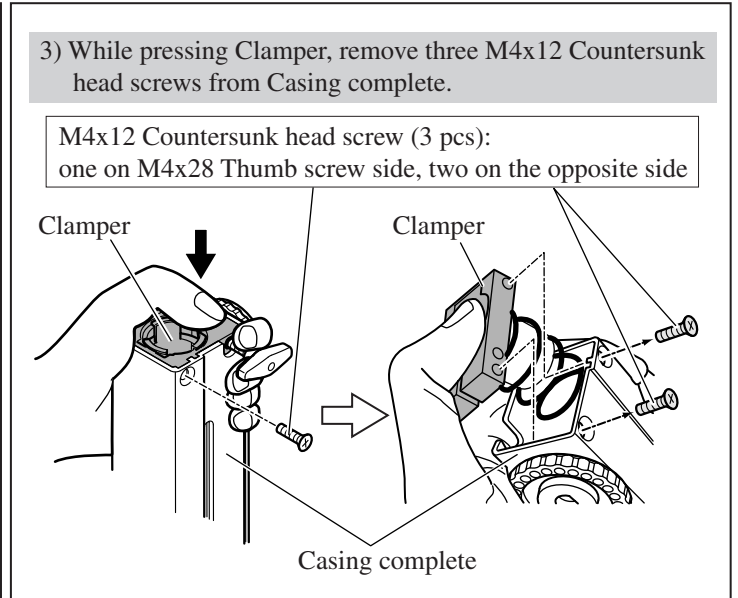

Fig. 4

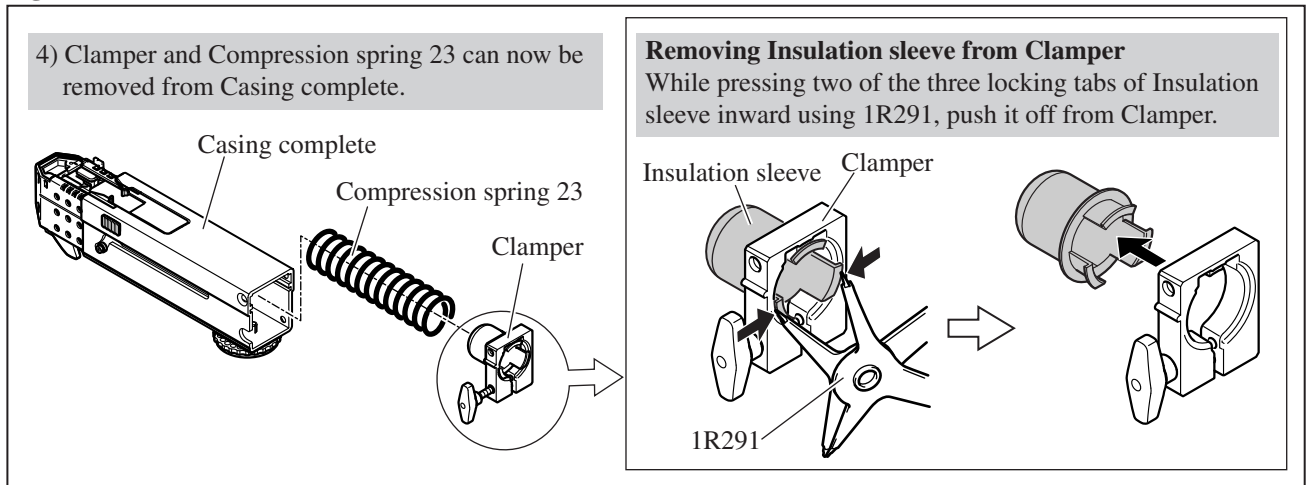

Fig. 5

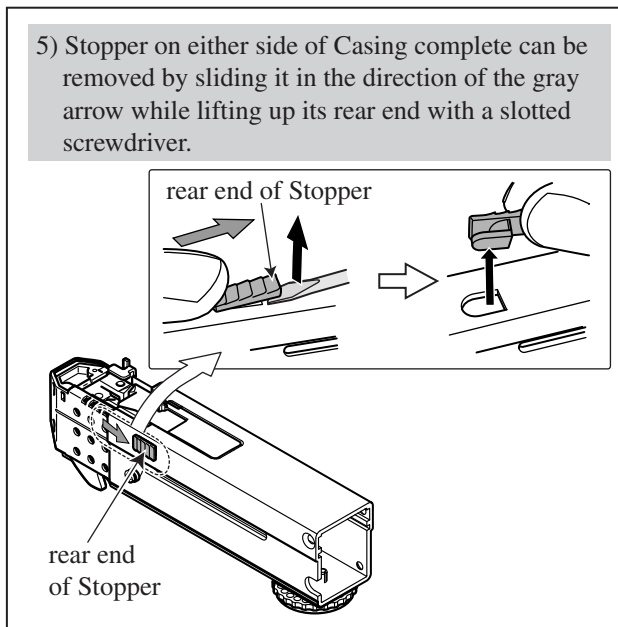
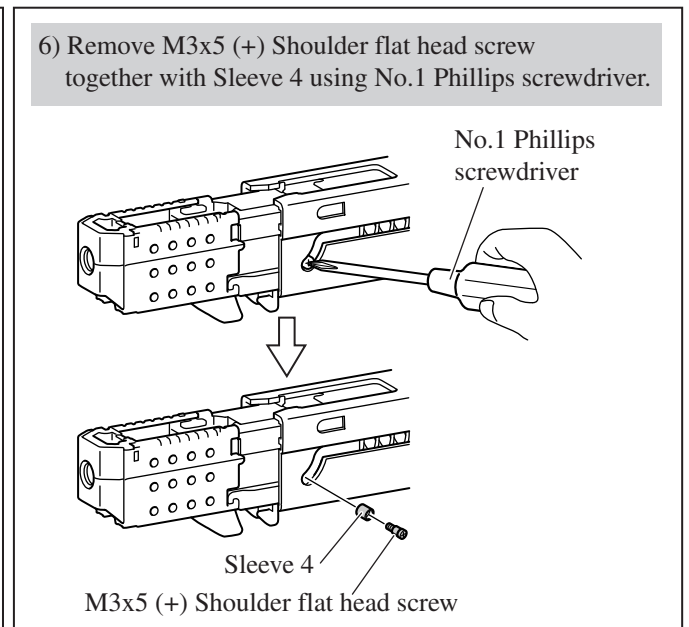

Fig. 6



► **Repair**

[3] DISASSEMBLY/ASSEMBLY

[3] -1. Casing Assembly and Feeder Box Assembly (cont.)

DISASSEMBLING

Fig. 7

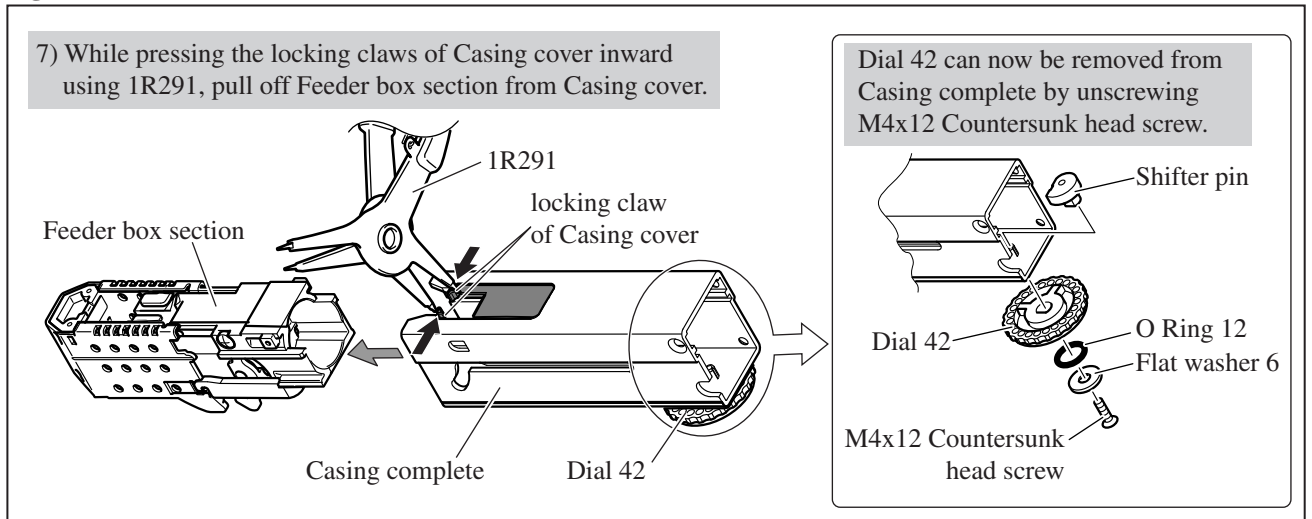

Fig. 8

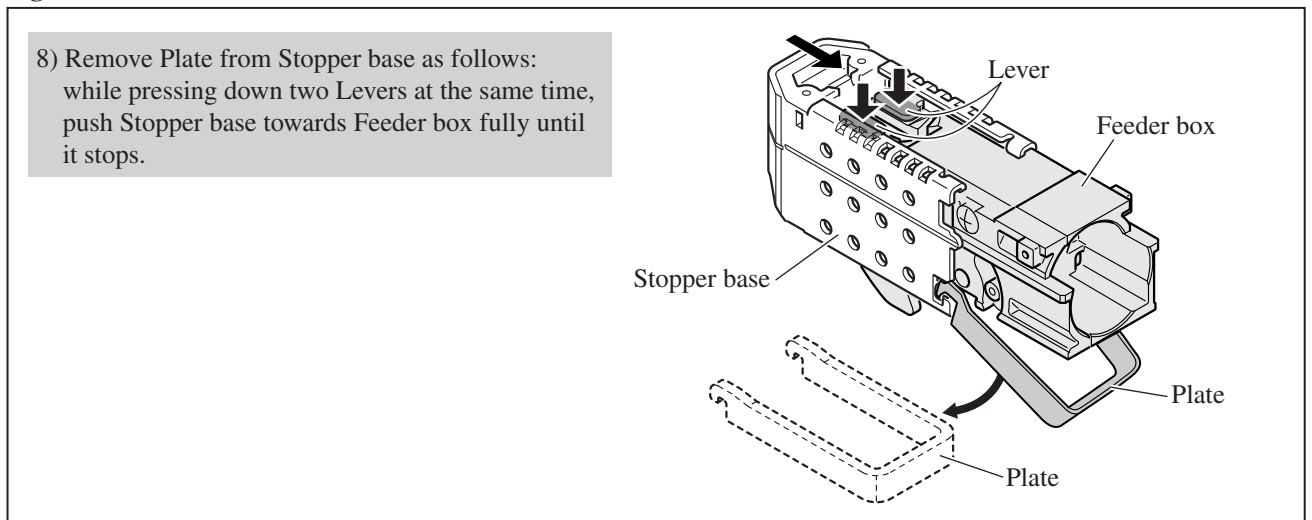

Fig. 9

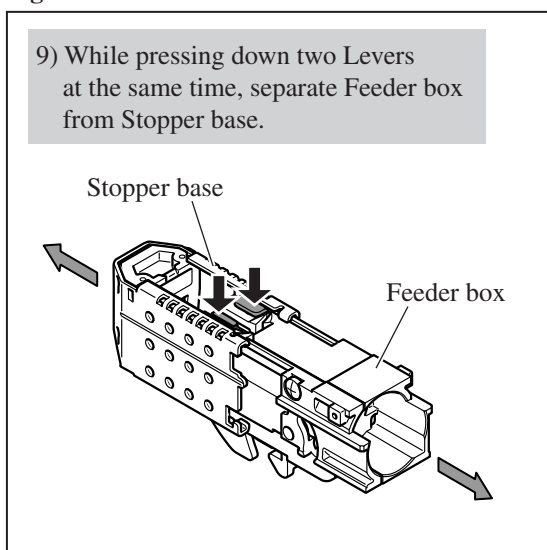
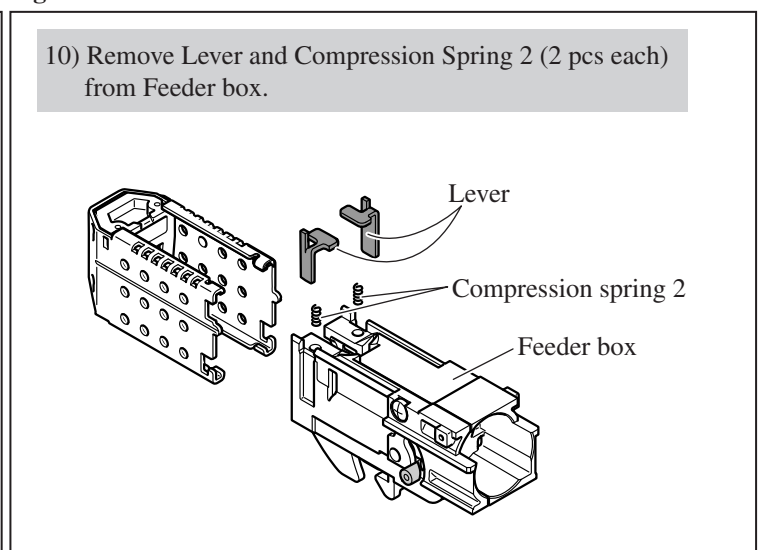

Fig. 10



► **Repair**

[3] DISASSEMBLY/ASSEMBLY

[3] -1. Casing Assembly and Feeder Box Assembly (cont.)

DISASSEMBLING

Fig. 11

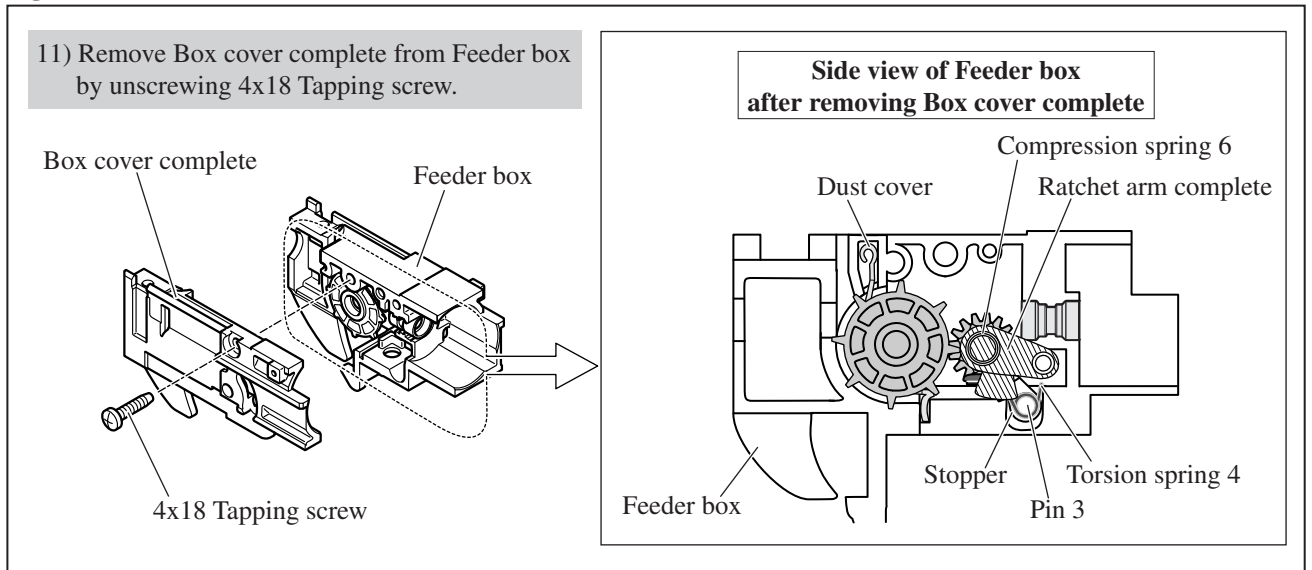

Fig. 12

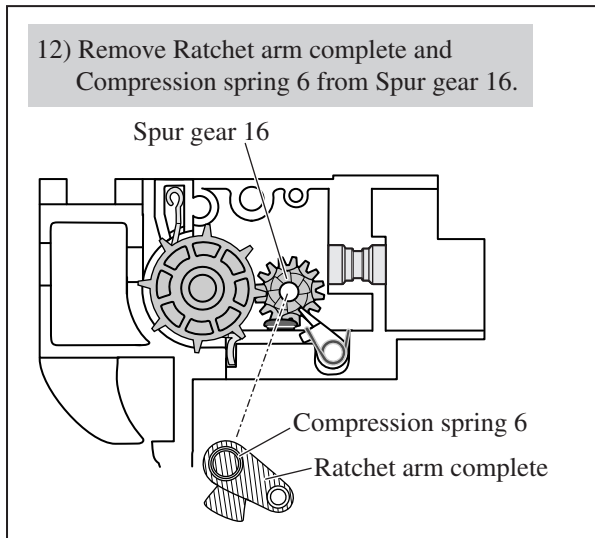

Fig. 13

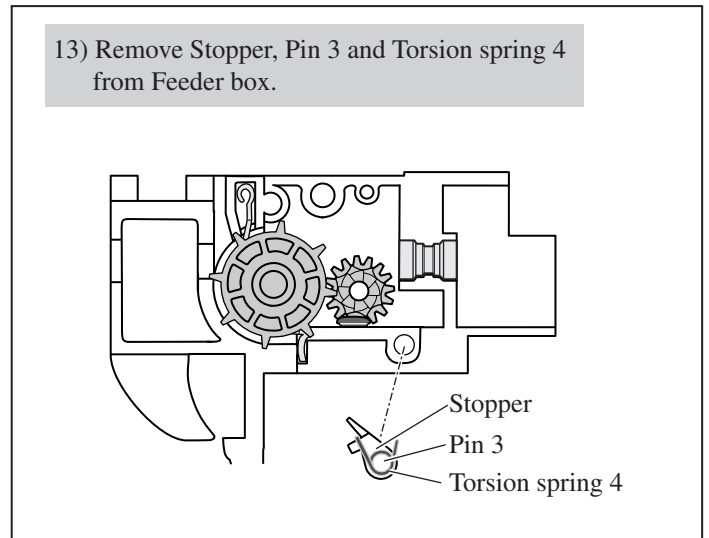
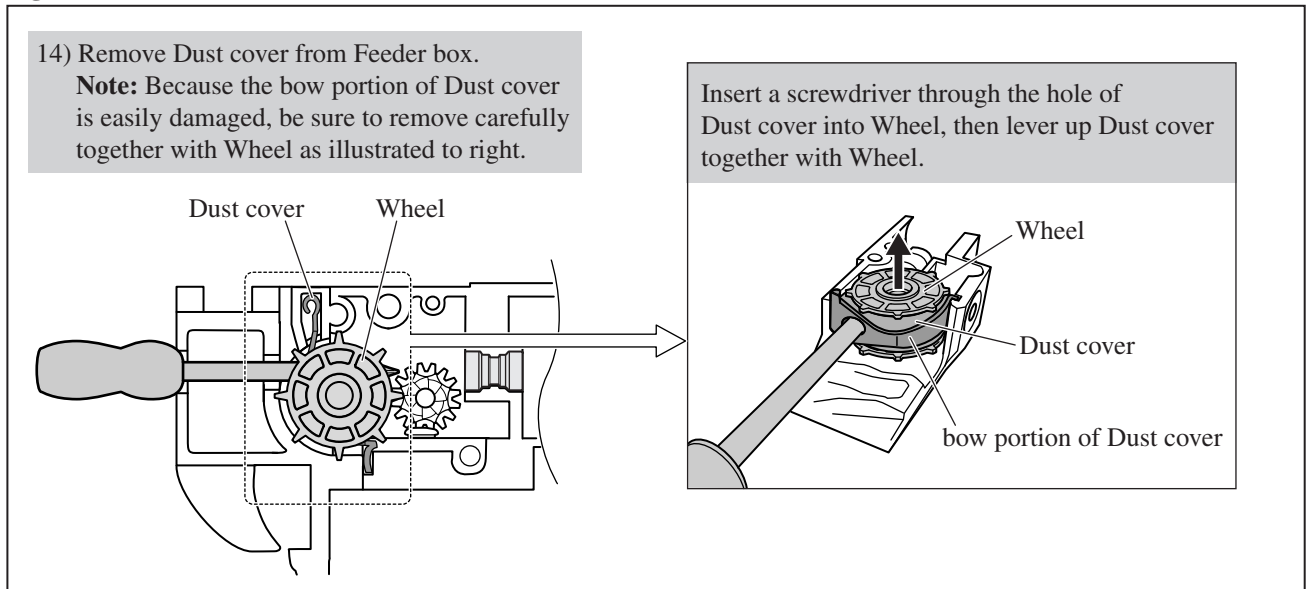

Fig. 14



► **Repair**

[3] DISASSEMBLY/ASSEMBLY

[3] -1. Casing Assembly and Feeder Box Assembly (cont.)

DISASSEMBLING

Fig. 15

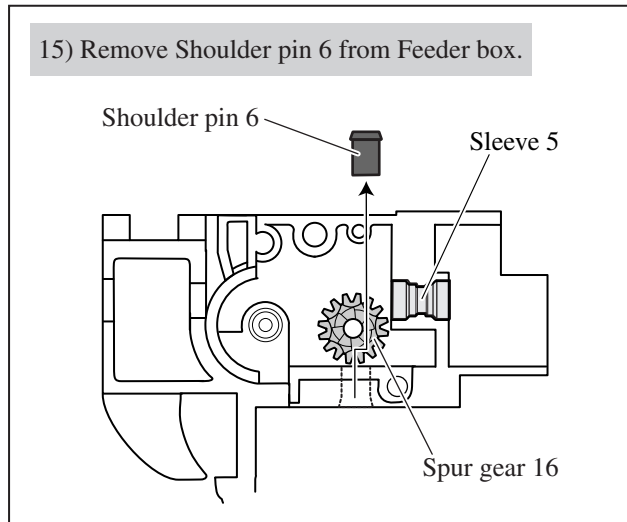

Fig. 16

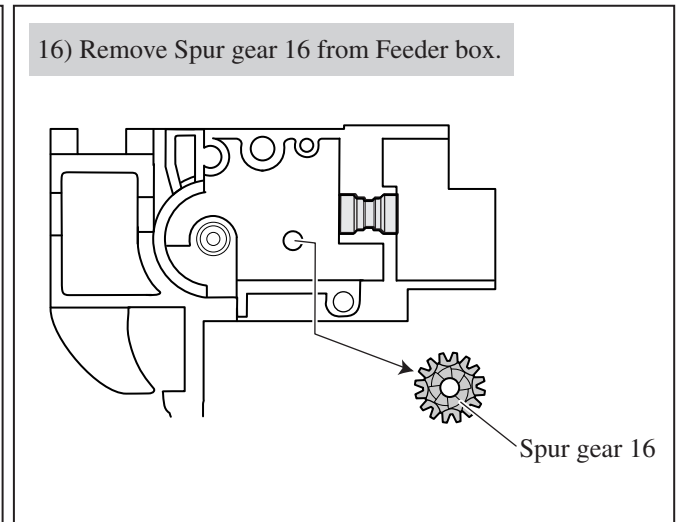
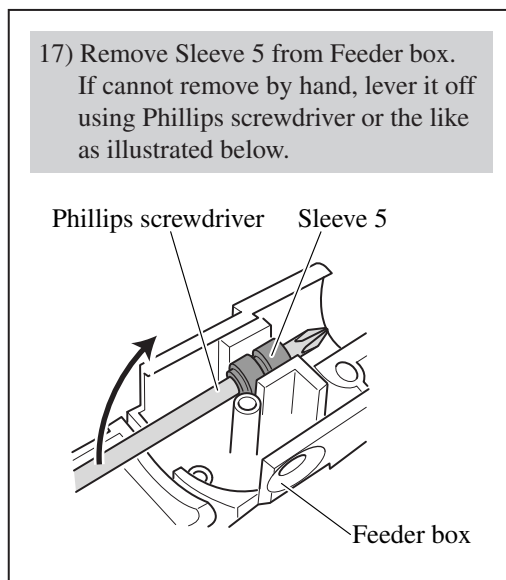

Fig. 17



► **Repair**

[3] DISASSEMBLY/ASSEMBLY

[3] -1. Casing Assembly and Feeder Box Assembly (cont.)

ASSEMBLING

- 1) Assemble Sleeve 5, Spur gear 16 and Shoulder pin 6 to Feeder box. (See Fig. 17 to Fig. 15 on page 6.)
- 2) Assemble Wheel together with Dust cover to Feeder box. (See Fig. 14.)

Important 1: Dust cover must be fixed securely to Feeder box as described in Fig. 18.

Important 2: Make sure that Wheel and Spur gear 16 are correctly engaged. (Fig. 19)

- 3) Assemble Pin 3 and Torsion spring 4 to Stopper (Fig. 20), then assemble them to Feeder box as described in Fig. 21.

Fig. 18

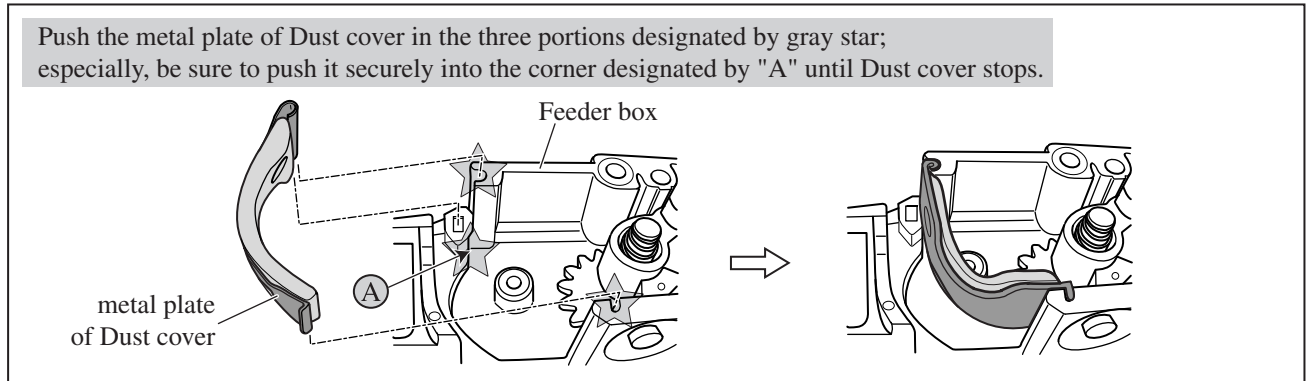

Fig. 19

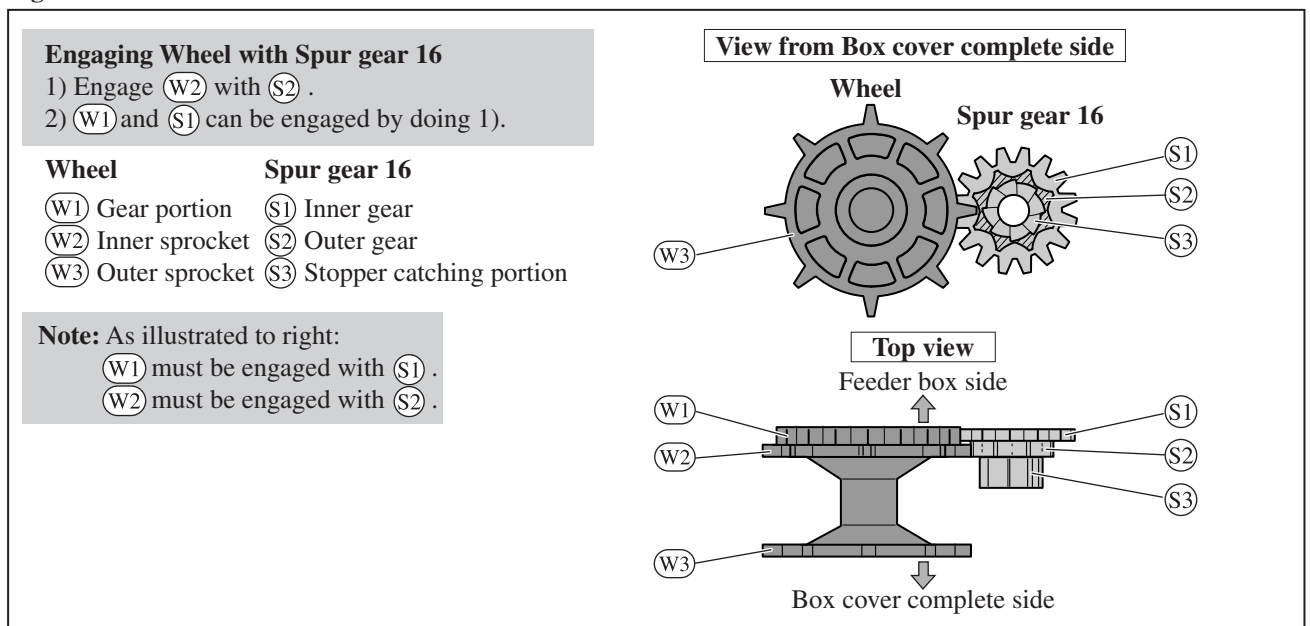

Fig. 20

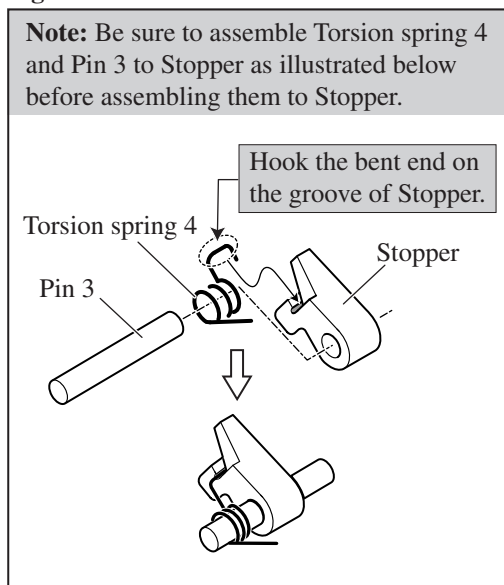
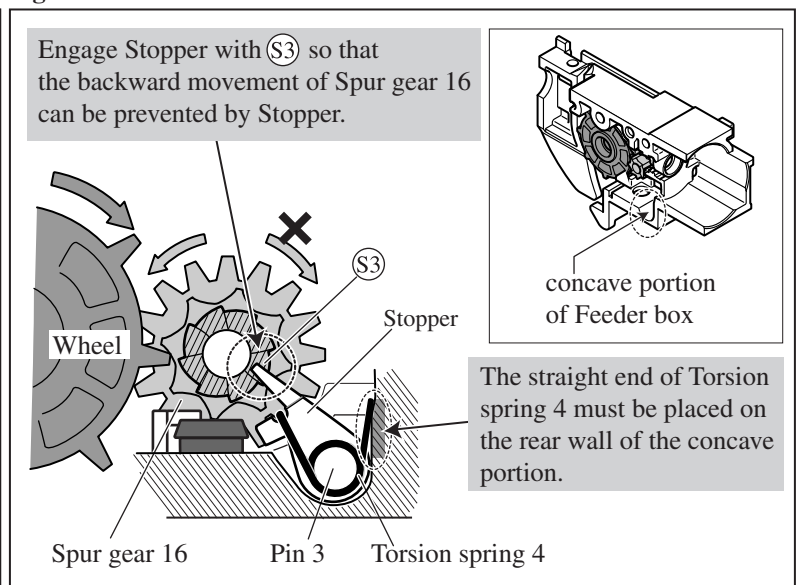

Fig. 21



► **Repair**

[3] DISASSEMBLY/ASSEMBLY

[3] -1. Casing Assembly and Feeder Box Assembly (cont.)

ASSEMBLING

- 4) Assemble Ratchet arm complete and Compression spring 6 to Spur gear 16. (See Fig. 12 on page 5.)
- 5) Assemble Box cover complete to Feeder box. (See Fig. 11 on page 5.)
- 6) Make sure that Wheel moves correctly as described in Fig. 22 by pushing Ratchet arm complete up and down .
- 7) Make sure that Wheel can be stopped by pushing in Shoulder pin 6. (Fig. 23)

Note:

Do not apply any lubricant oil/grease or anticorrosive oil to the parts illustrated in Fig. 24. because smooth feeding can be prevented by dirt and dust sticking to such oily/greasy parts.

Fig. 22

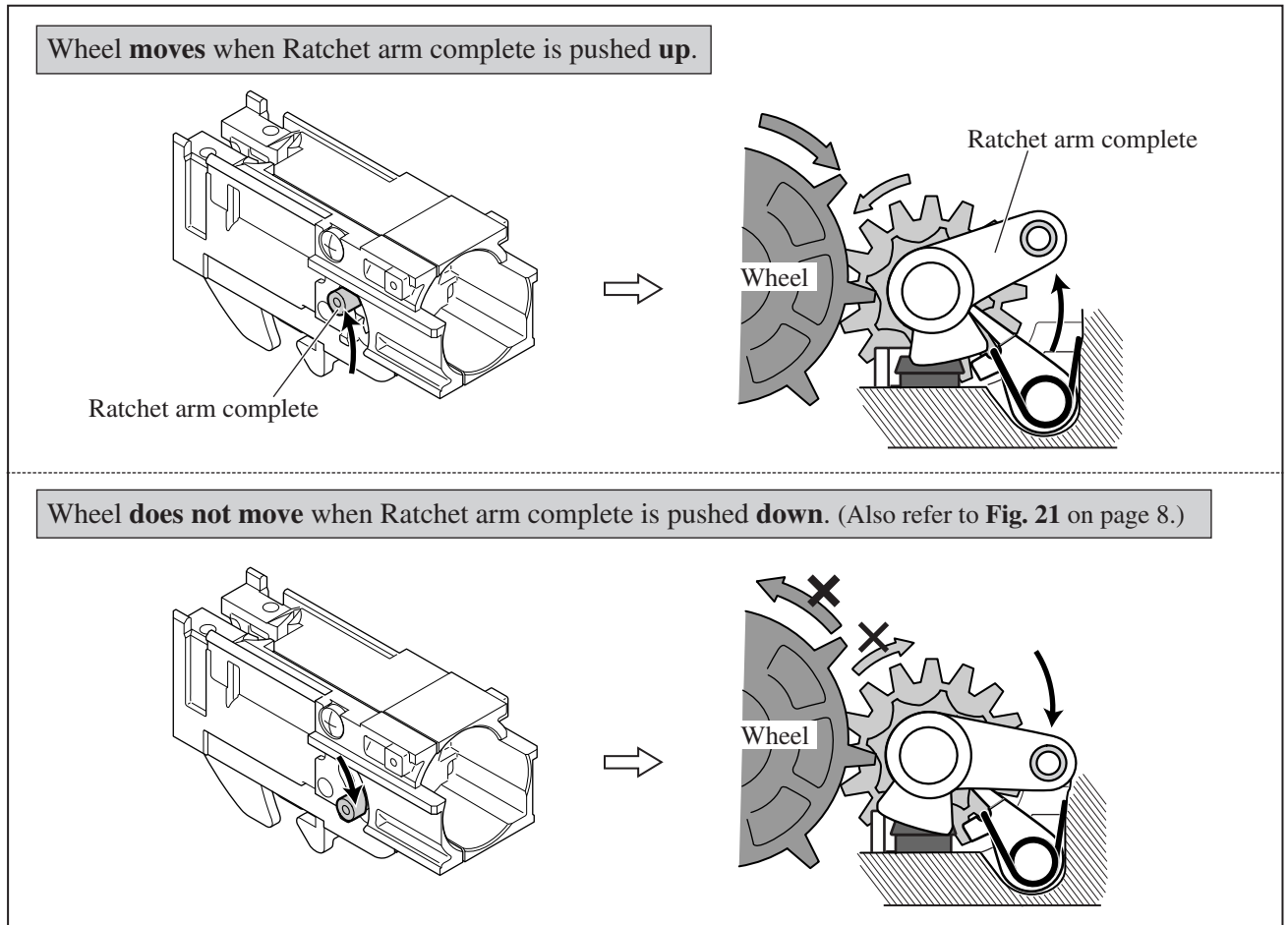

Fig. 23

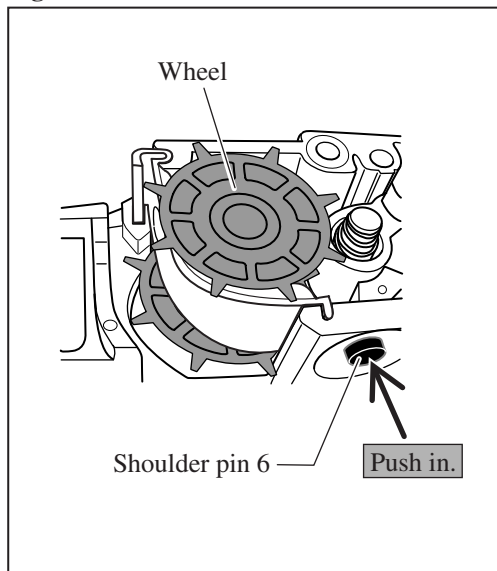
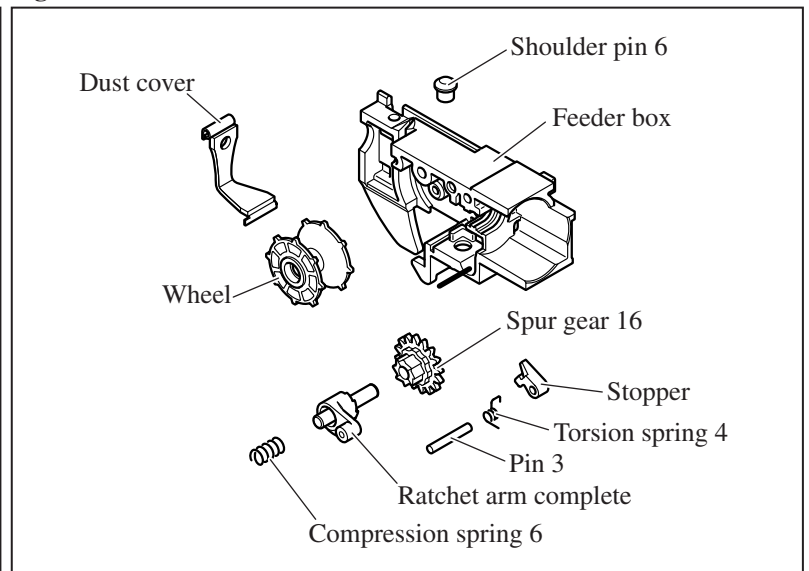

Fig. 24



► **Repair**

[3] DISASSEMBLY/ASSEMBLY

[3] -1. Casing Assembly and Feeder Box Assembly (cont.)

ASSEMBLING

8) Casing complete can be assembled by doing the reverse of the disassembling steps. (**Fig. 7** to **Fig. 2** on pages 4 to 3)

Note: Be sure to follow the instructions described in **Fig. 25** to **Fig. 27**.

Fig. 25

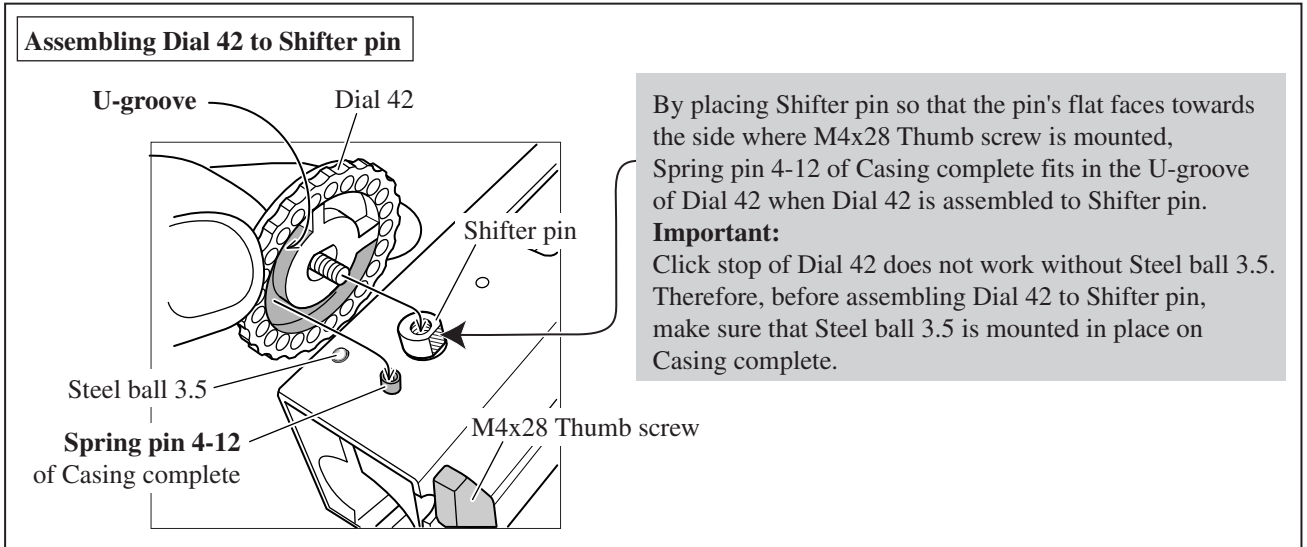

Fig. 26

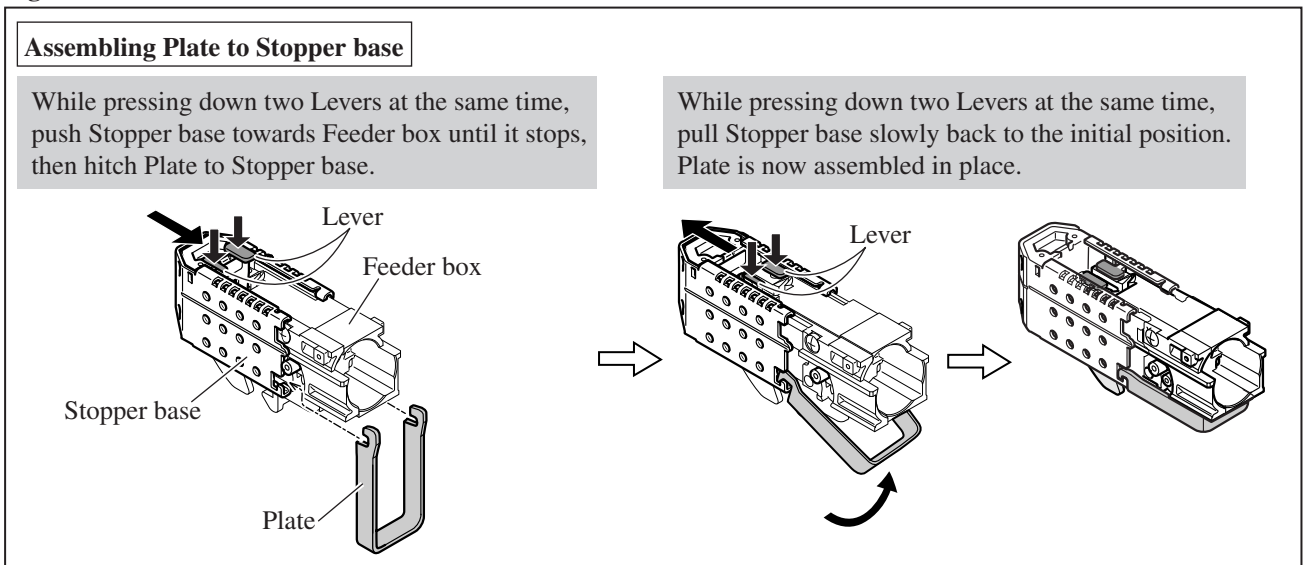
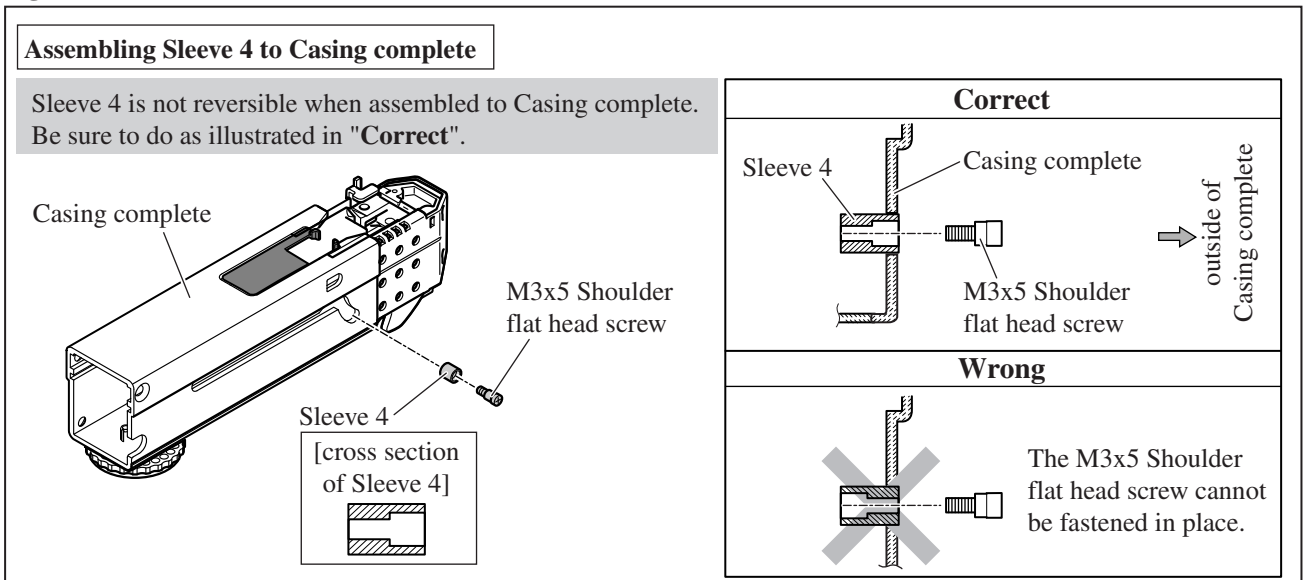

Fig. 27



► **Repair**

[3] DISASSEMBLY/ASSEMBLY

[3] -2. Stopper Base Section

DISASSEMBLING

Disassemble by taking the steps described in **Fig. 28** to **Fig. 31**.

Fig. 28

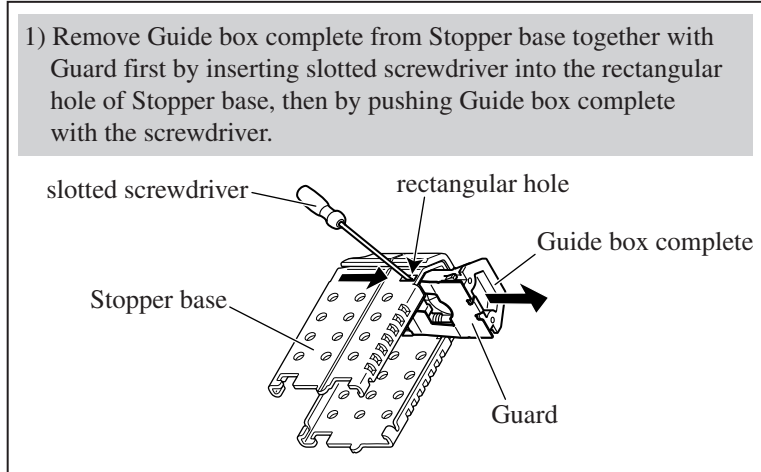

Fig. 29

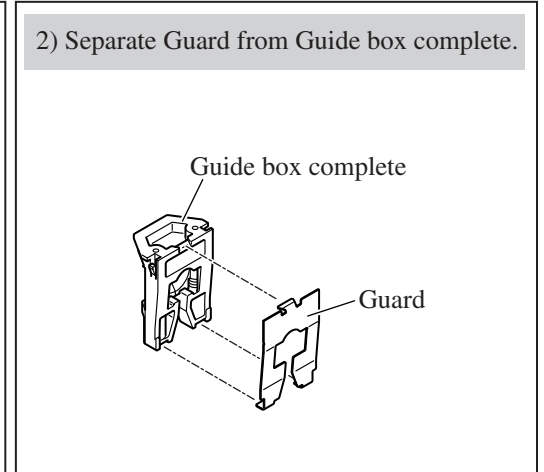

Fig. 30

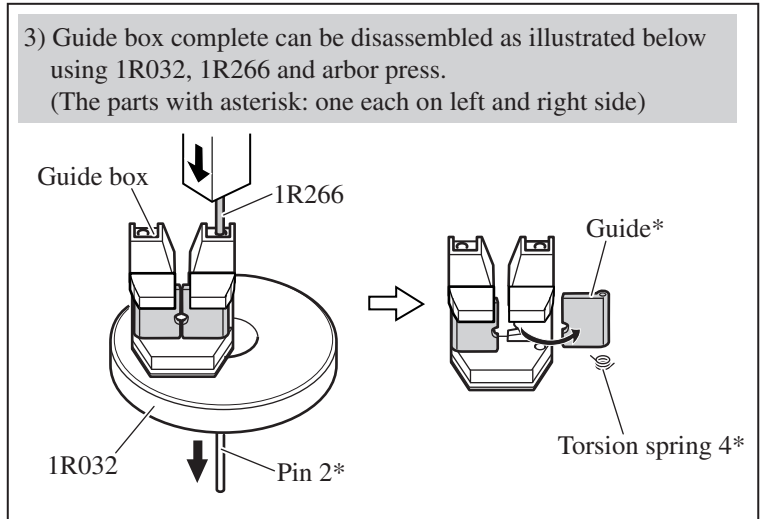
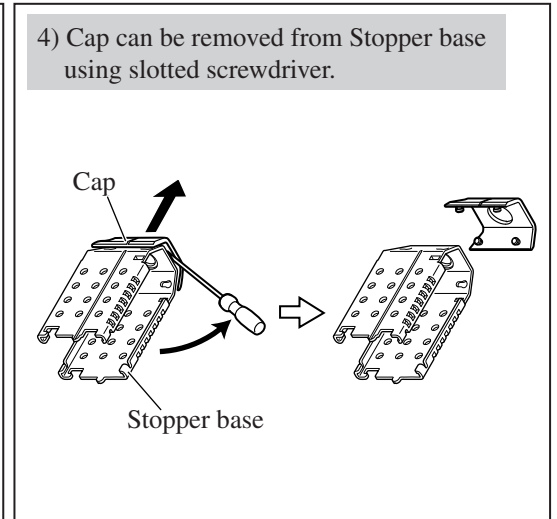

Fig. 31



[3] -3. Clutch Section and Helical Gears

DISASSEMBLING

Disassemble by taking the steps described in **Fig. 32** to **Fig. 37**.

Fig. 32

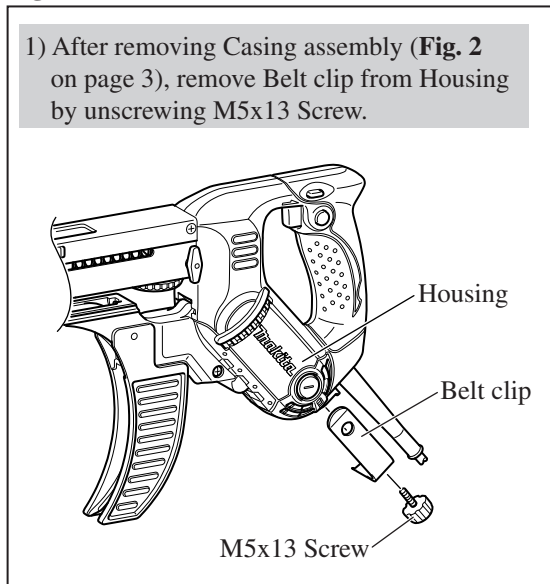
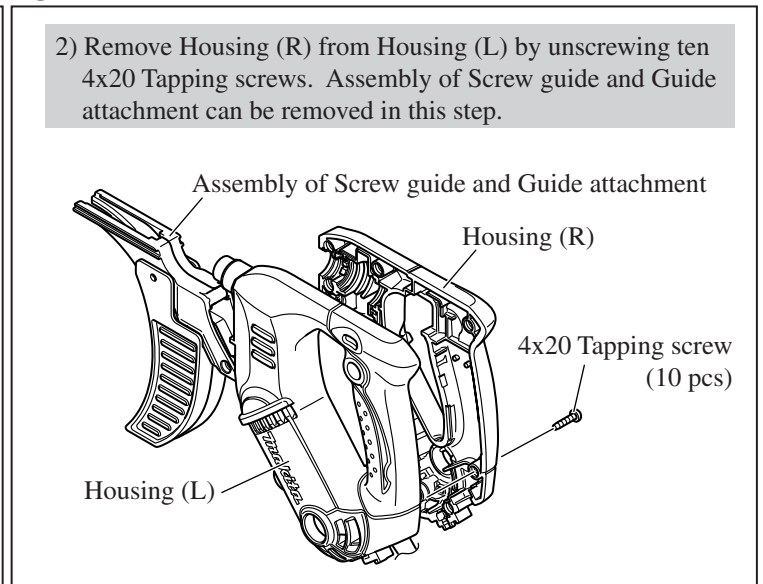

Fig. 33



► **Repair**

[3] DISASSEMBLY/ASSEMBLY

[3] -3. Clutch Section and Helical Gears (cont.)

DISASSEMBLING

Disassemble by taking the steps described in Fig. 32 to Fig. 37.

Fig. 34

3) Remove Clutch section from Housing (L).

From the removed Clutch section, Ball bearing 608 and Assembly of Helical gear (large) will be separated by the force of Compression spring 25.

Assembly of Helical gear (large) consisting of:
Helical gear (large), Clutch cam C, Steel ball 4 (3 pcs), Flat washer 26, Compression spring 25

Assembly of Helical gear (small) can be also removed in this step.

Note:
Different gears are used for Helical gear (large) and Helical gear (small) by model as listed below. Be careful not to confuse them.

	Model 6842	Model 6843	Model 6844
Helical gear (large)	Helical gear 57	Helical gear 53	Helical gear 60
Helical gear (small)	Helical gear 13	Helical gear 16	Helical gear 9

Fig. 35

4) The rest of Clutch section can be disassembled by hand as illustrated below.

Fig. 36

5) Assembly of Helical gear (large) can be disassembled by hand as illustrated below.

Fig. 37

6) Assembly of Helical gear (small) can be disassembled by hand as illustrated below.

► **Repair**

[3] DISASSEMBLY/ASSEMBLY

[3] -3. Clutch Section and Helical Gears (cont.)

ASSEMBLING

Assemble by taking the steps described in **Fig. 38** to **Fig. 40**.

Fig. 38

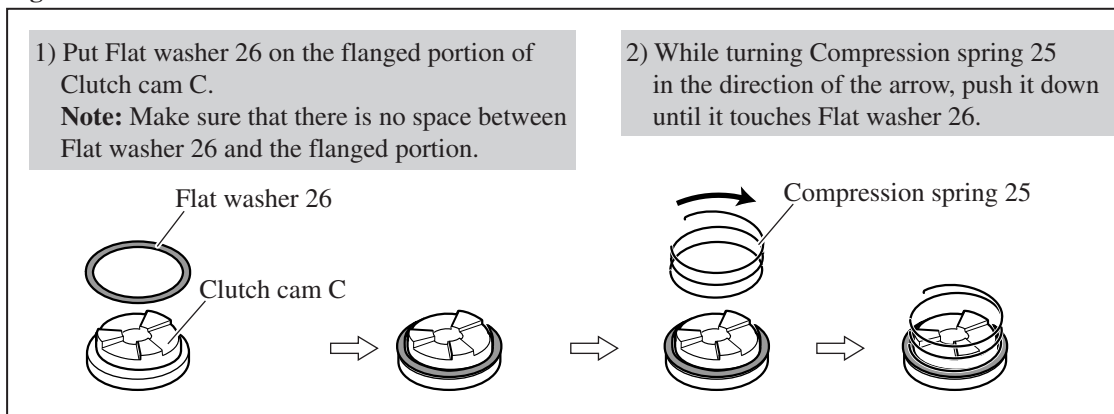

Fig. 39

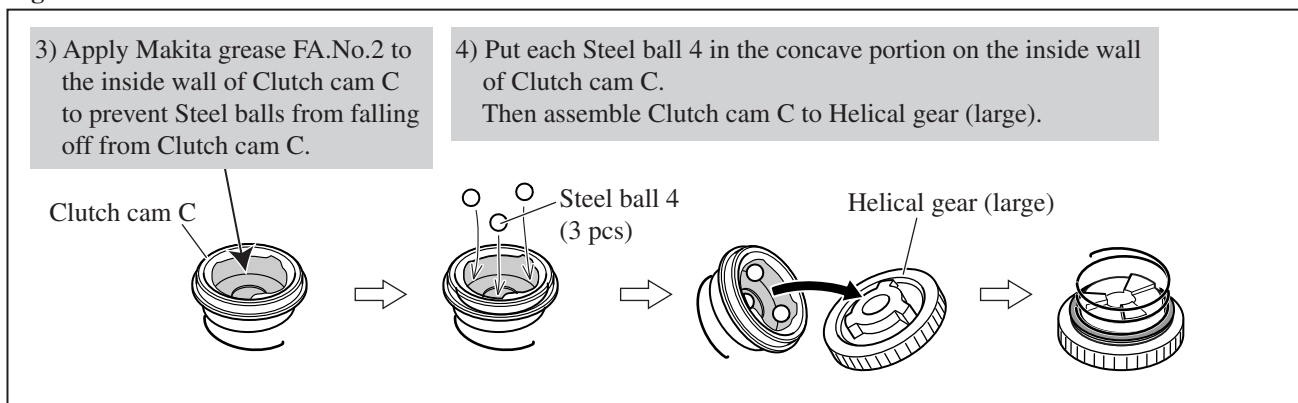
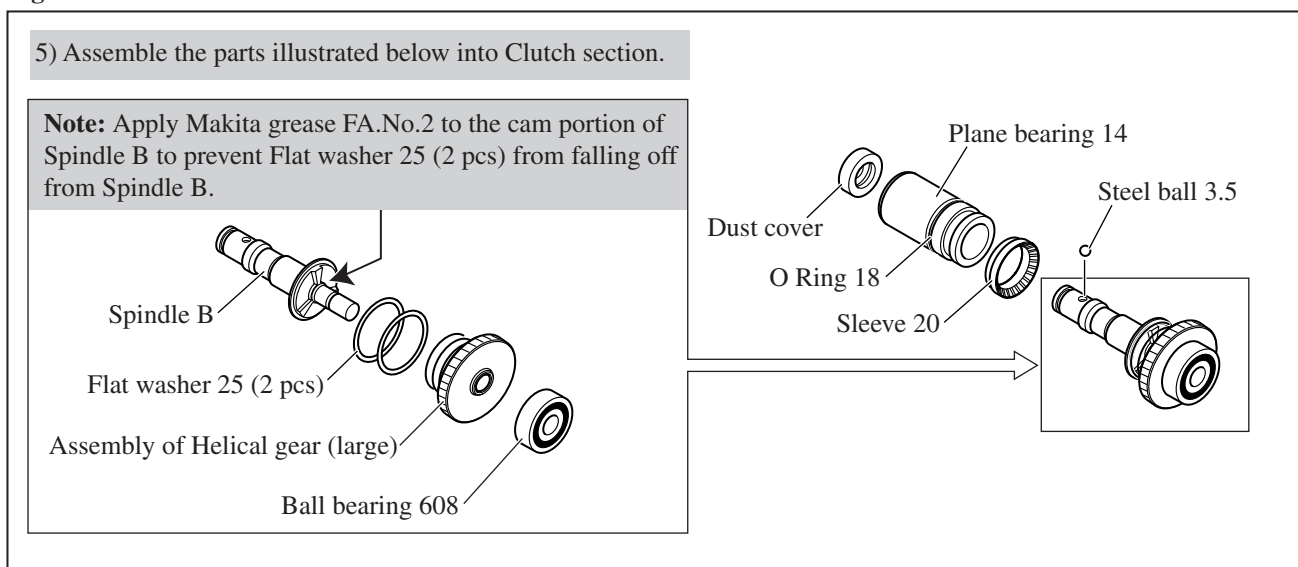

Fig. 40



► **Repair**

[3] DISASSEMBLY/ASSEMBLY

[3] -4. Motor Section

DISASSEMBLING

- 1) Remove Casing assembly (Fig. 2 on page 3).
- 2) Disassemble Housing (R) from Housing (L). (Figs. 32, 33 on page 10)
- 3) Disassemble Motor section by taking the steps described in Fig. 41 to Fig. 43.

Fig. 41

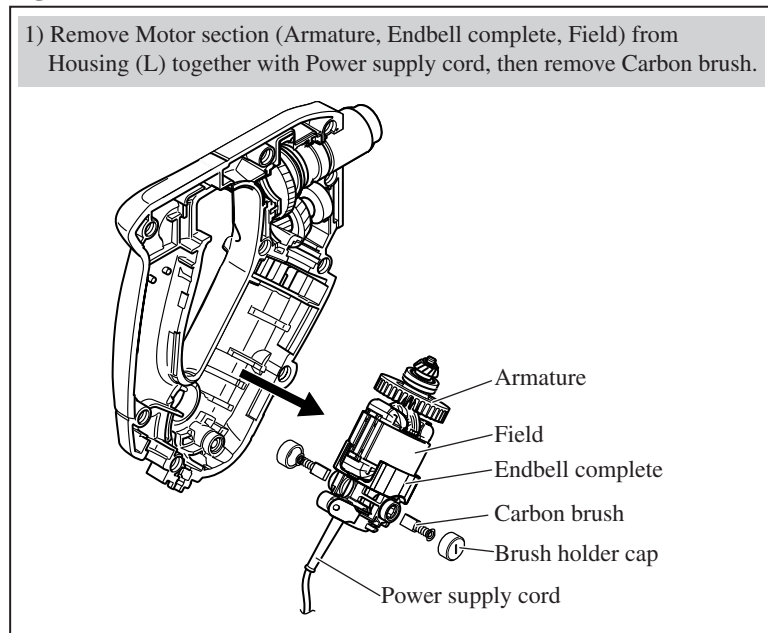

Fig. 42

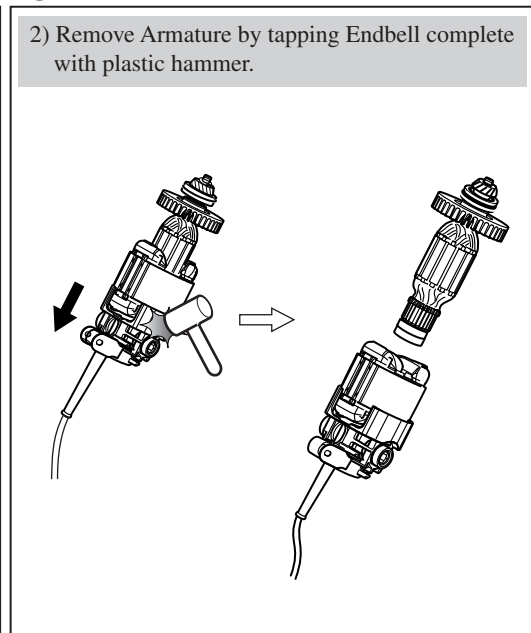
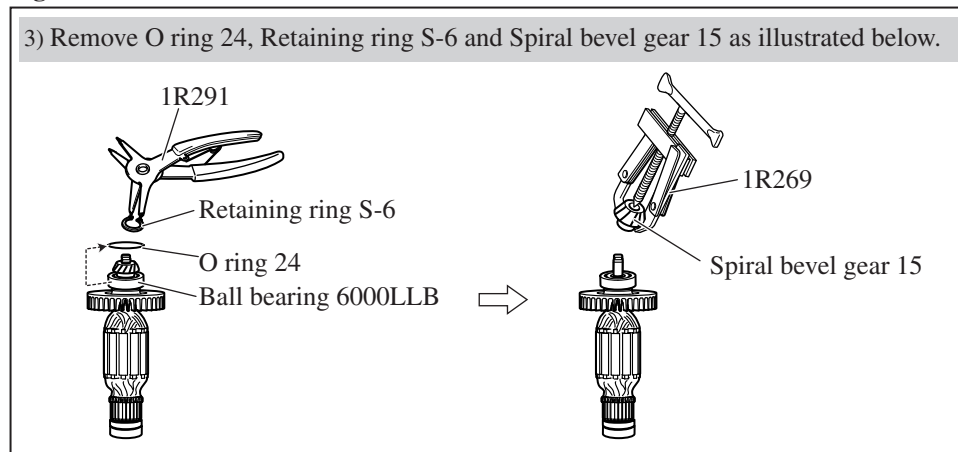

Fig. 43



ASSEMBLING

Do the reverse of the disassembling steps.

Note: Do not forget to mount O ring 24 on Ball bearing 6000LLB. (left in Fig. 43)

[3] -5. Switch

ASSEMBLING





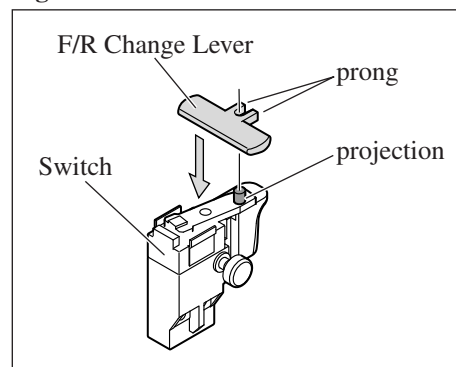

Put the projection on Switch between the prongs of F/R change lever, then assemble the Switch to Housing (L). (Fig. 44)

Fig. 44



► **Circuit diagram**

Fig. D-1

Color index of lead wires' sheath			
Black		Orange	
White		Purple	
Red		Clear	

Note on Noise suppressor

- 1) Noise suppressor and Earth terminal (Ground terminal) are not used for some countries.
- 2) Some countries use two-wire Noise suppressor.

The color of Lead wire to Brush holder

- Ⓐ **Orange** wire is connected to Brush holder on **Housing (L)** side.
- Ⓑ **Purple** wire is connected to Brush holder on **Housing (R)** side.

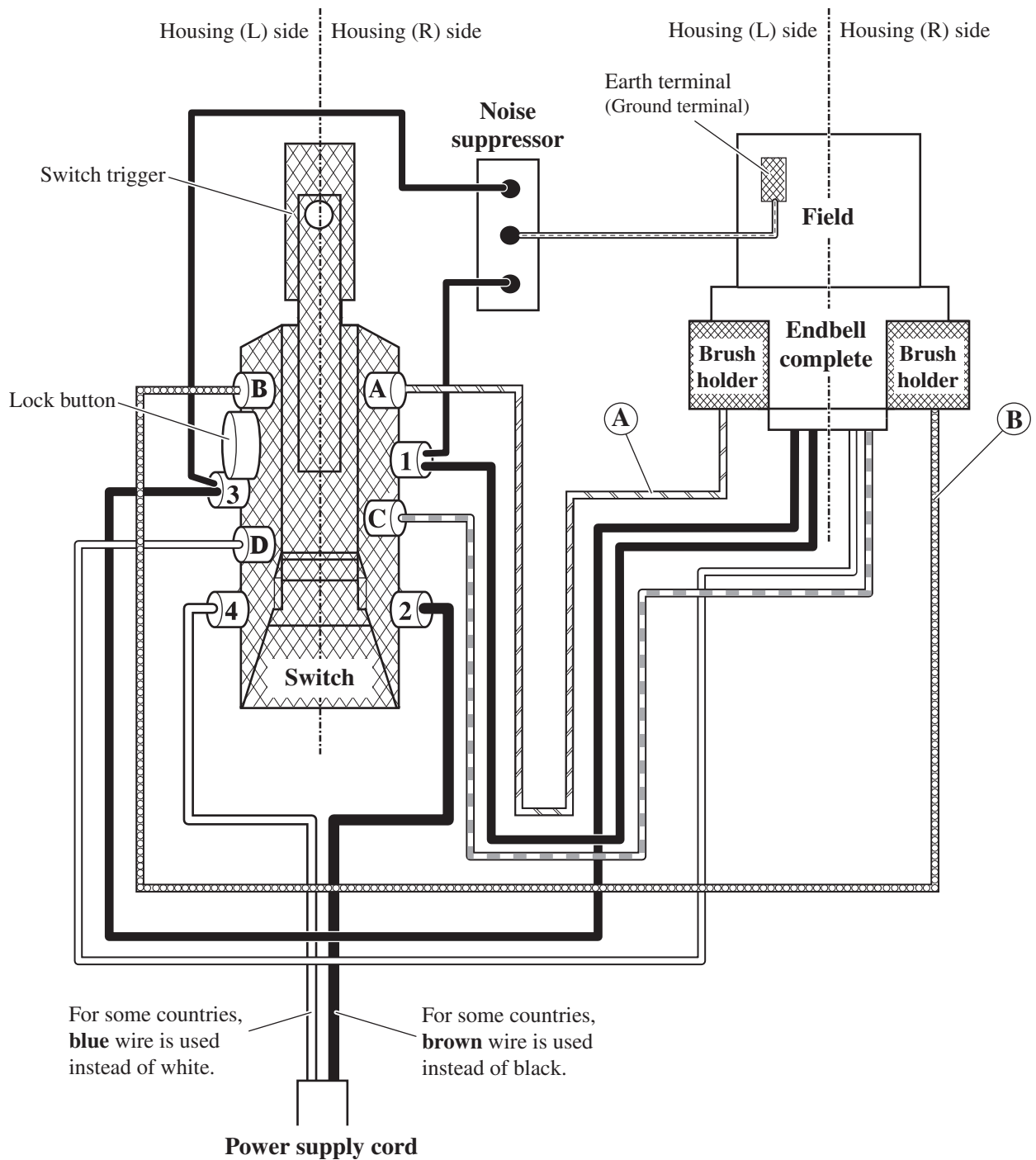

► **Wiring diagram**

[1] Wiring on Endbell Complete

Route Lead wires on Endbell complete as described in **Figs. D-2, D-3** (viewed from Housing (L) side) and **Fig. D-4** (viewed from Field side).

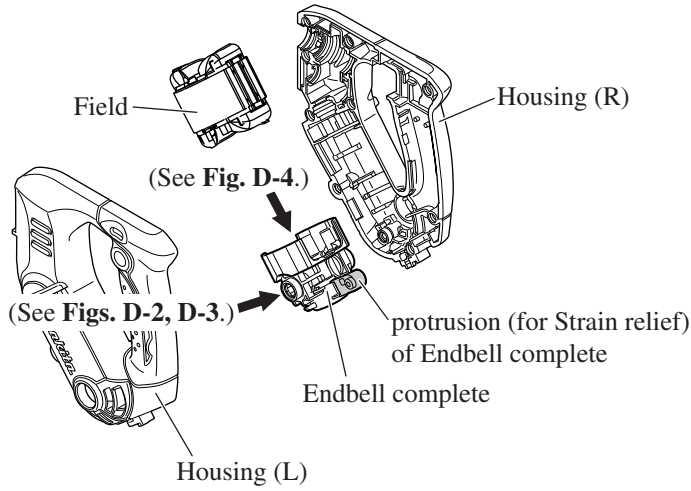

Fig. D-3

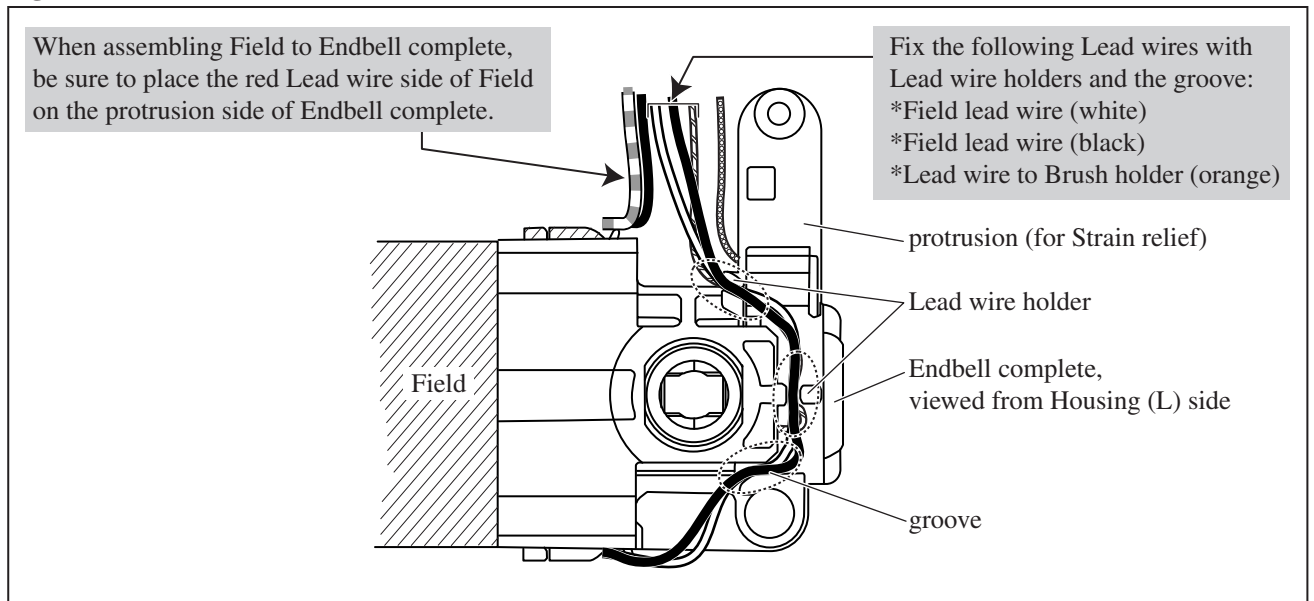

Fig. D-4

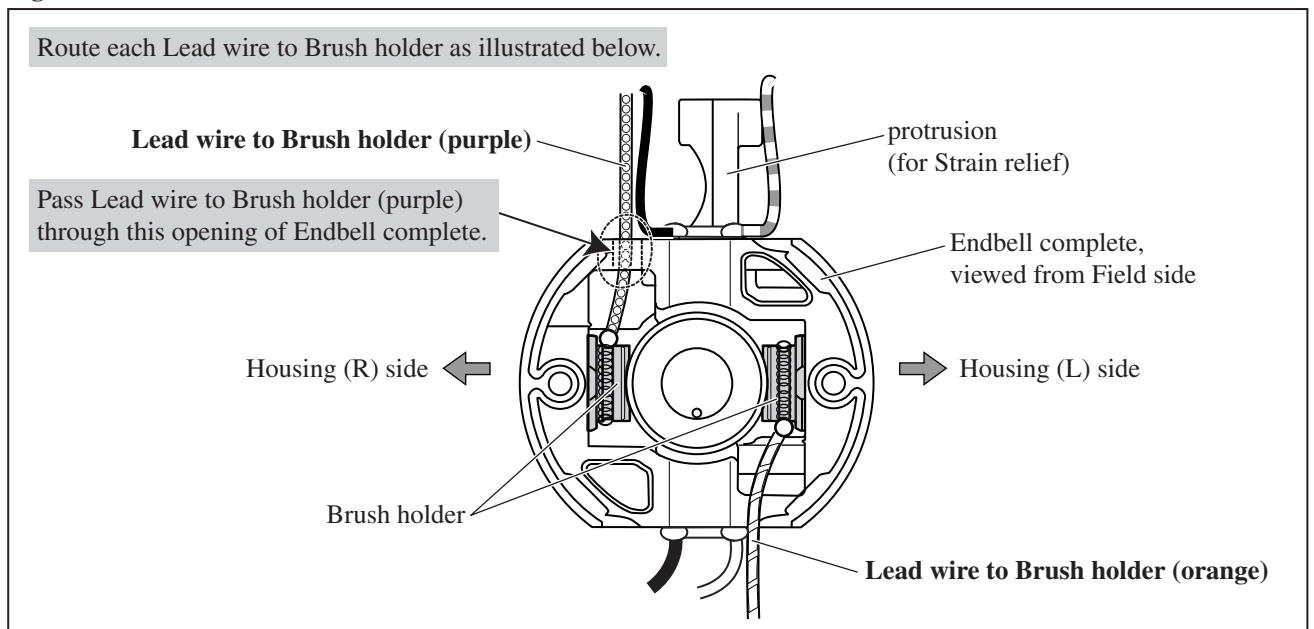
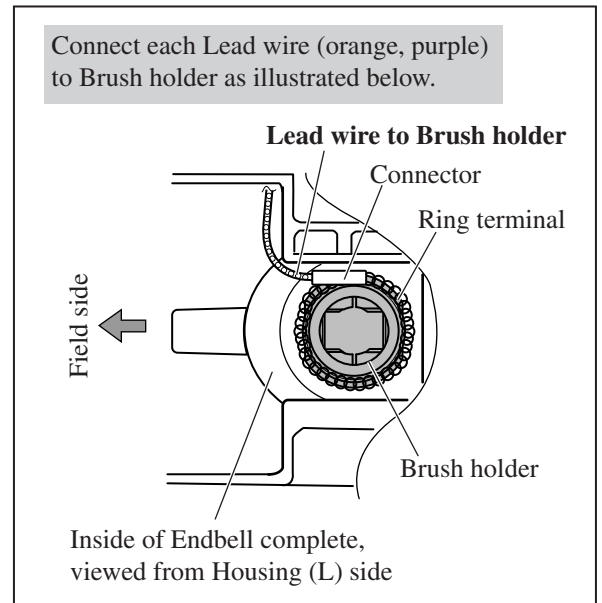

Fig. D-2



► **Wiring diagram**

[2] Wiring in Housing

Note: Noise suppressor and Earth terminal (Ground terminal) are not used for some countries.

Fig. D-5

