

T ECHNICAL INFORMATION

Makita

New Tool

Models No. ▶ 6903VD/VDW

Description ▶ Cordless Impact Driver

CONCEPTION AND MAIN APPLICATIONS

Model 6903VD/VDW was developed to increase the maneuverability of Model 6901VD/VDW.

It offers slimmer, more easily gripped handle for better-balanced, faster and more accurate driving actions.

Model 6903VD is sold with a battery cartridge 9100 but without a fast charger.

Model 6903VD includes a battery cartridge 9100 and a fast charger DC9700.

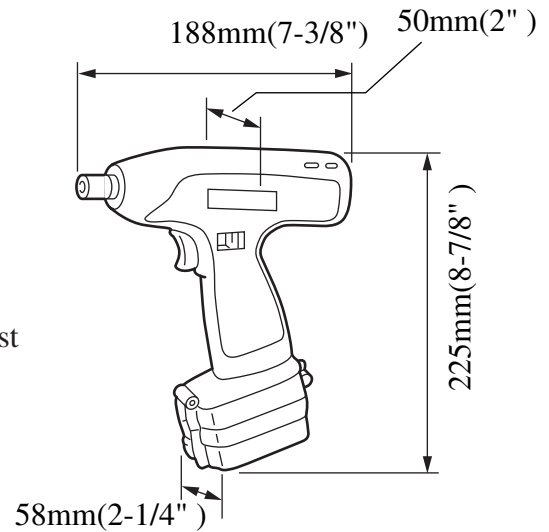

▶ Specifications

DC Magnet Motor (9.6V)

No Load Speed	0-2,200 R/min.
Impact per minute	0-2,800
Max. tightening torque	700Kg.cm (50 fit. lbs)

Capacities

Machine screw and bolt	4mm(5/32")-10mm(3/8")
Net Weight	1.3Kg(2.9 lbs)

▶ Standard equipment

Fast Charger DC9700 (Model 6903VDW only), Battery Cartridge 9100,
Phillips Bit 2-65, 3-65, Bit Piece,
Plastic Carrying Case (Model 6903VDW only)

The standard equipment for the tools shown may differ form country to country

▶ Optional accessories

Phillips Bit 2-45, 2-65, 2-82, 2-110, 2-150, 2-250, 3-45, 3-65, 3-110,
Socket Bit 7-55, 8-55, 10-55, 10-70, 12-86,13-55, 14-55, 17-55,
Bit Piece, Keyless Drill Chuck, Drill Chuck (Conventional type), Fast Charger DC9012,
Fast Charger DC9700, Battery Cartridge 9100

▶ REPAIR

Assembling

1. Flat washer between spindle complete and spur gear has to be installed in the housing without separating it from ball bearing.
2. Taping screws have to be fastened with the fastening torque, 12 - 16 Kgfc \cdot m.

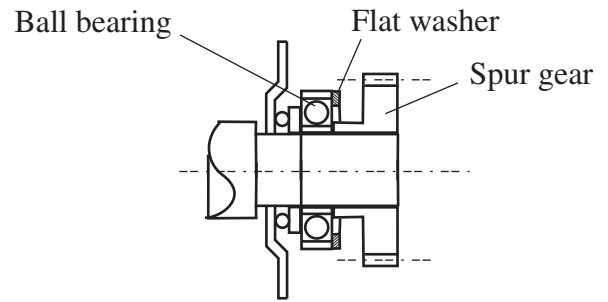

▶ CIRCUIT DIAGRAM

