

**For Models** ▶ 6905H

**Description** ▶ Impact Wrench

## CONCEPTION AND MAIN APPLICATIONS

Priced much lower than the existing Model 6905B, yet its capacities and functions are the same as the Model 6905B. Incredible light (2.3kg ; 5.1 lbs) and well-balanced for an impact wrench of this power.

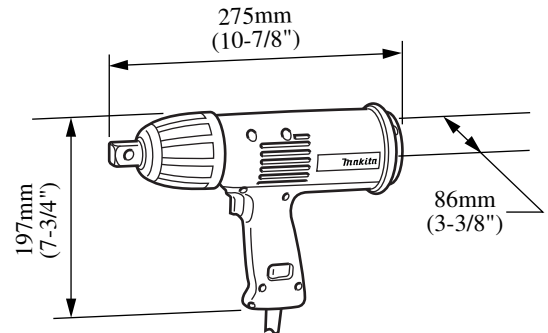

### ► Specifications

Voltage(V)	Current(A)	Cycle(Hz)	Continuous Rating(W)		Max. Output(W)
			Input	Output	
100	4.9	50/60	470	200	340
115	4.3	50/60	470	200	340
200	2.5	50/60	470	200	340
220	2.2	50/60	470	200	340
230	2.1	50/60	470	200	340
240	2.0	50/60	470	200	340

### ► Capacity

**Standard bolt** : M12-M20(7/16"-3/4")

**High tensile bolt** : M12-M16(7/16"-5/8")

**Square Drive** : 12.7mm(1/2")

**No load speed** : 2,200R/min

**Impacts per min** : 2,600

**Max.Fastening Torque** : 3,000kg.cm(217ft.lbs)

**Net weight** : 2.3kg(5.1 lbs)

### ► Standard equipment

Socket 19-40, 22-42, 24-43.5, Steel Carrying Case

### ► Optional accessories

Various size of Sockets, Extension Bar 12.7, Universal Joint 12.7, Oval Socket, Time Switch