

TECHNICAL INFORMATION



New Tool

Models No. ▶ 6913D

Description ▶ Cordless Impact Driver

CONCEPTION AND MAIN APPLICATIONS

Light 1.6 kg (3.5 lbs), short 194 mm (7-5/8"), yet powerful 12 V Cordless Impact Driver.

This tool is handy for fastening lag screws 50 mm (2") to 120 mm (4-3/4") long.

Model 6913DH is sold with a battery cartridge 1201 but without a fast charger.

Model 6913DWH includes a battery cartridge 1201 and a fast Charger DC1201.

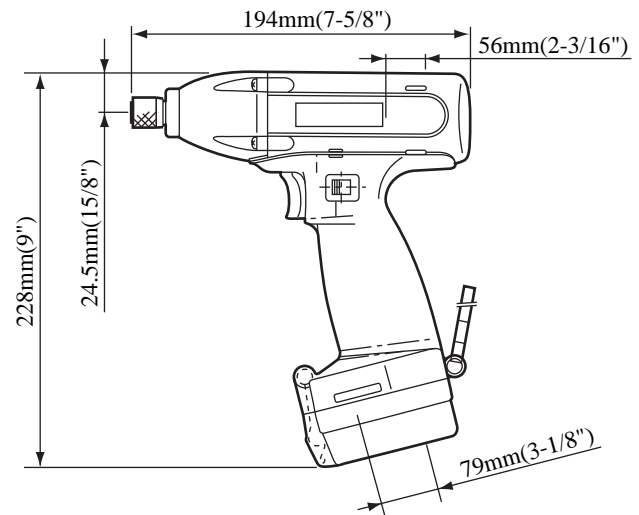

► Specifications

DC Magnet Motor (12V)

Capacities	Machine screw	M4 (5/32") -M8 (5/16")
	Standard bolt	M5(3/16") -M12(1/2")
	High tension bolt	M5(3/16") -M10(3/8")
No Load Speed	0 -2,200 R/min.	
Impacts per minute	0 -3,000	
Max. fastening torque	1,000 Kg. cm (72.3 ft. lbs)	
Net Weight	1.6 Kg (3.5 lbs)	

► Standard equipment

Fast charger DC1201 (6913DWH only), Battery cartridge 1201, Phillips Bit 2-65, Battery cover, Plastic carrying case (6913DWH only)

► Optional accessories

Phillips bit 2-65, 3-65, Bit piece, Various sizes of socket bit, Keyless chuck set, Drill chuck set, Battery cartridge 1200, 1201, 1201A, Fast charger DC1201