

T ECHNICAL INFORMATION



New Tool

Models No. ▶ 6931D

Description ▶ Battery powered impact wrench

CONCEPTION AND MAIN APPLICATIONS

The number of impacts can be set on the wrench with the counter switch, which automatically stops its operation after the preset number of impacts are given. Because of this feature, you can tighten bolts at the constant torque with this impact wrench.

The model 6931DW is compared with 6931D, charger DC1401 and Battery 1402.

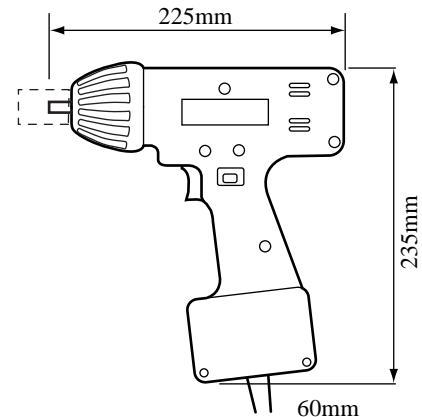

► Specifications

Motor	DC14.4V Magnetic Motor
No Load Speed	0 -1,900 r.p.m.
Impacts per minute	0 - 2,300/min.
Anvil size	1/2" (12.7mm)
Net Weight	1.6 Kg

Impact number setting range : 4 to 196 impacts (Set with the counter switch at 02 to 98.)

Tightening torque (max.) 1500kgf-cm (108 ft-lbs)

Tightening capacity : Regular bolts M12 to M16 (1/2" to 5/8")

High tension bolts M8 to M12 (3/16" to 1/2")

► Optional accessories

Pin 4, O-ring 26, O-ring 22, socket 12-75, socket 17-39, socket 17-52, socket 19-40, socket 19-52, socket 21-41, socket 21-52, socket 22-42, socket 22-52, socket 23-43, socket 23-52, socket 24-43.5, socket 24-52, socket 21-80, socket 19-80, socket 13-36, socket 13-52, socket 14-36.5, socket 14-52, bit adapter (leaf spring & steel ball 3.5), extension bar 12.7, universal joint 12.7, and elliptical socket.

Troubles and repairs (Use the table for your trouble-shooting)

Troubles	Causes	Solutions
1. The motor pulsates in the speed change switch operating range.	a) The switch is faulty.	a) Replace the switch.
2. The motor pulsates and does not produce power as required.	a) Voltage dropped	a) Charge the battery.
3. The motor does not rotate. (in the forward direction only)	a) The impact number setting counter is set at 00 or 01.	a) Set the counter at other number than 00 or 01, as the motor does not rotate at the 00 or 01 setting.
4. The motor does not rotate. (in the forward and backward rotation.)	a) The motor is faulty. b) The switch is faulty. c) The control circuit is faulty.	a) Replace the motor. b) Replace the switch. c) Replace the control circuit.
5. The wrench does not automatically stop after the preset number of impacts is completed.	a) The impact number setting counter is set at 99. b) The wrench operates with the motor in the backward rotation. c) The control circuit is faulty.	a) The impact number is not detected when the setting is at 99. Set the counter between 02 and 99. b) The impact number is detected only when the motor rotates in the forward direction. c) Replace the control circuit.

The same mechanical parts such as the motor, gears, spindle complete assembly, hammer, and anvil, etc. are used as for the model 6902D. Therefore, you can follow the same steps to repair the mechanical parts of this model as of the model 6902D

