

For Models ▶ 6951

Description ▶ Impact Driver

## CONCEPTION AND MAIN APPLICATIONS

This new impact driver is developed as an improved model of the current #6950 and its main features are as follows:-

1. A new reverse switch, located near the trigger switch, ensures one-hand operation.
2. A new trigger switch with variable speed control has a wider variable speed control length of trigger for easier operation.
3. Ergonomics design of handle for comfortable operation.

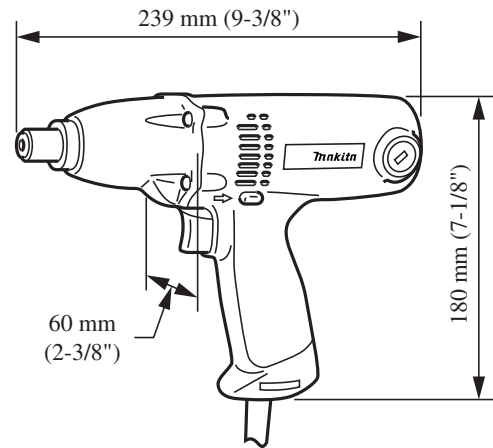

### ► Specifications

Voltage(V)	Current(A)	Cycle(Hz)	Continuous Rating(W)		Max. Output(W)
			Input	Output	
100	3.2	50/60	300	120	280
120	*2.8	50/60	300	120	280
200	1.6	50/60	300	120	280
220	1.5	50/60	300	120	280
230	1.4	50/60	300	120	280
240	1.3	50/60	300	120	280

\*U.S.A., CANADA : 120V, 3.2A

<b>No Load Speed</b>	0~2200rpm/min
<b>Impact per minute</b>	0~3000
<b>Net Weight</b>	1.3kg (2.9lbs)
<b>Power Supply Cord</b>	2.5m (8.2ft)

### ► Standard equipment

- Phillips Bit 2-65...1
- Plastic Carrying Case...1

### ► Optional accessories

- Phillips Bit 2-65, 3-65 Stopper (for depth adjustment of screw) Socket Bit 7-55, 8-55, 10-55, 10-70, 12-86, 13-55, 14-55, 17-55, 17-65, Bit piece

The Standard equipment for the tools shown may differ from country to country.

(4) Attaching Spindle complete and Hammer assembly to Housing :  
Joint Flat washer with Ball bearing as the right figure, and place them into Housing.

(5) Attaching of Ball bearing 607LB :  
As only one side is sealed in Bearing of Armature rear part, direct an open side toward the rear end and attach it.

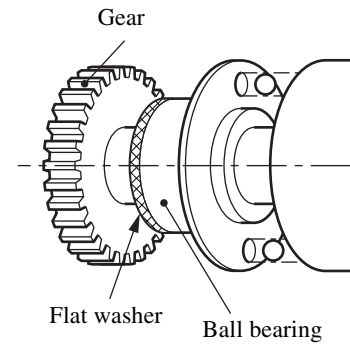

Fig. 3

(6) Disassembly of Hammer  
Press down Hammer with Arbor, put the insert entrance of Steel ball in Hammer together with the cum groove top of Spindle as the right Figure.4, and pull out Steel ball. Then, direct Hammer downward and remove Spindle complete, being careful that Steel ball inside Hammer may not fall out.

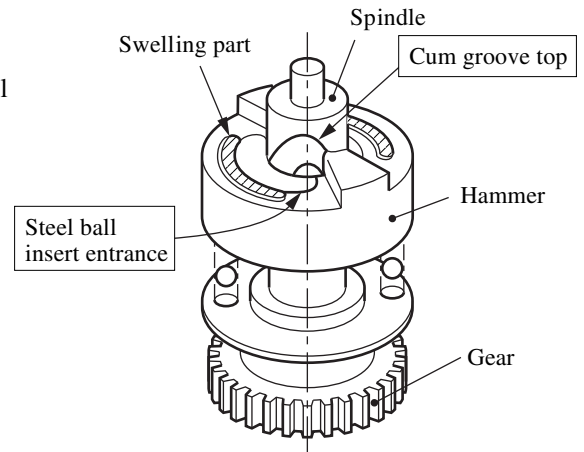

Fig. 4

(7) Notes in Field exchange

Since Lead wires go out of the both ends in Field as Fig. 1, install as Fig. 2 so that Yellow terminal plate may be located in Fan side of Armature.

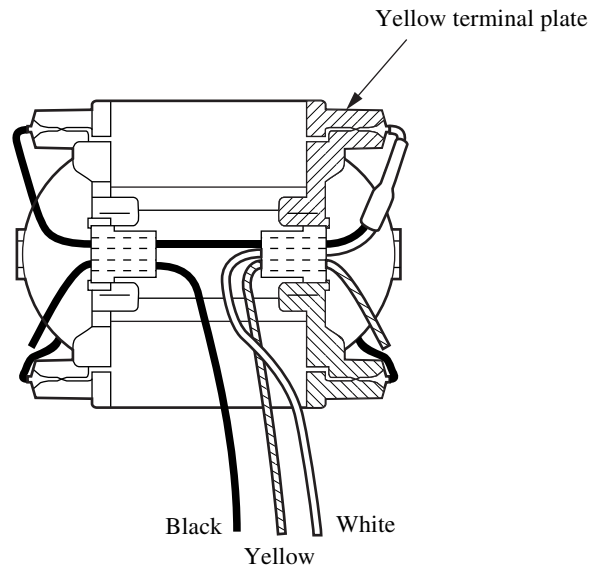

Fig. 1

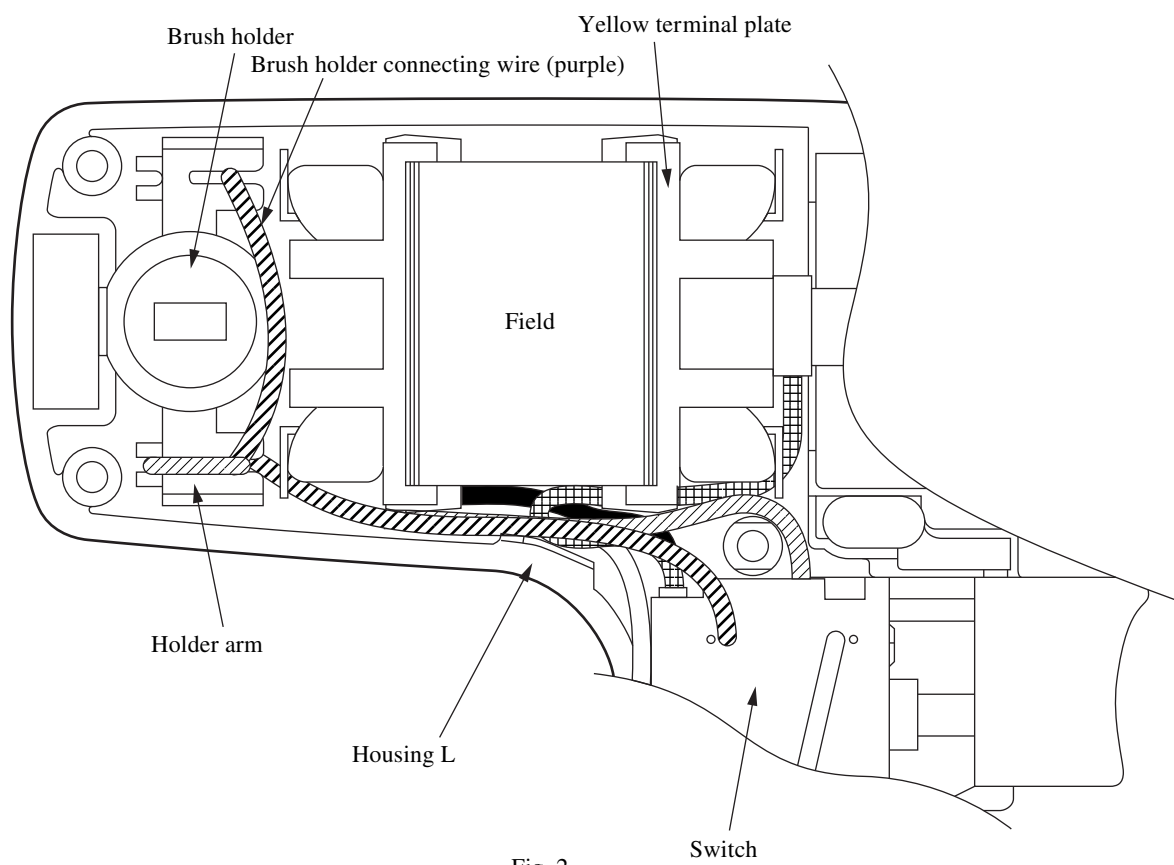
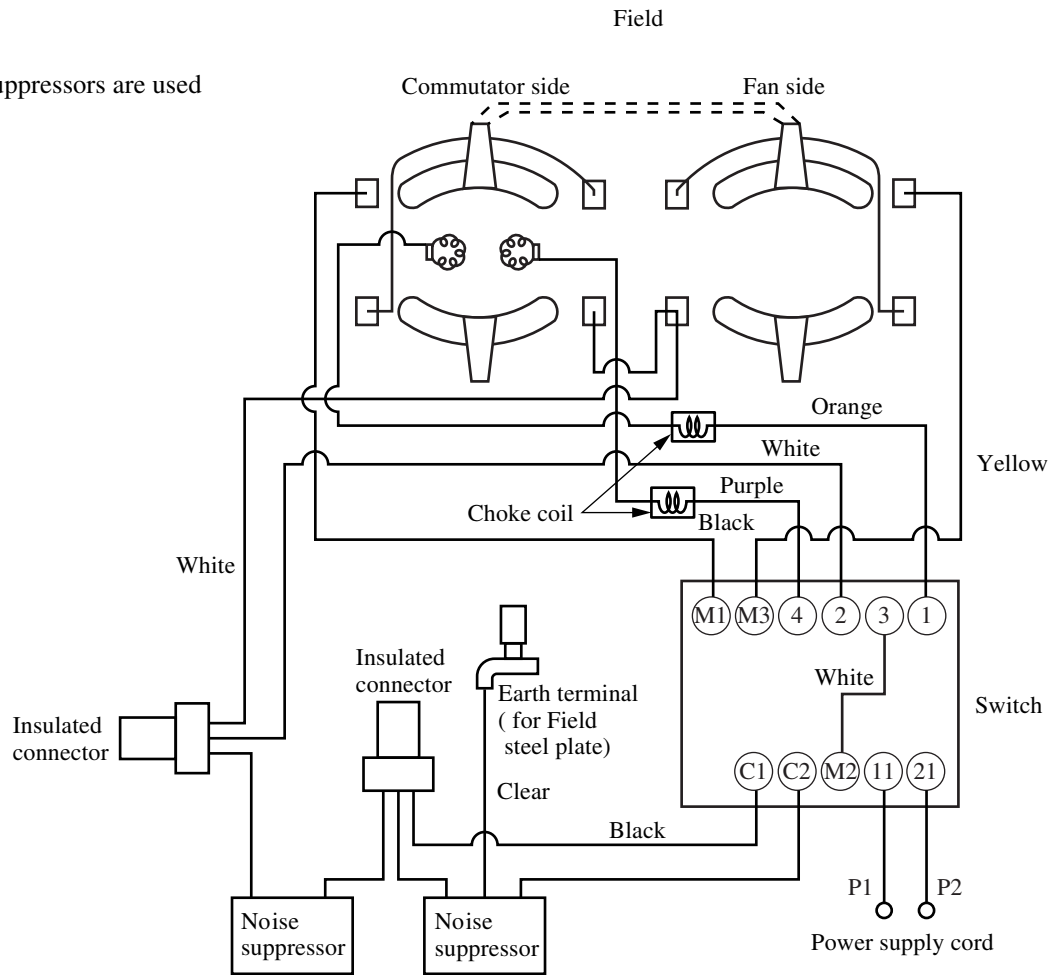

Fig. 2

## ► Circuit diagram

Area where two Noise suppressors are used



Other area

There are areas where neither Choke coil nor Noise suppressor is used.

