

T ECHNICAL INFORMATION



New Tool

Models No. ▶ 8400VD

Description ▶ 10mm (3/8") Cordless Hammer Drill

CONCEPTION AND MAIN APPLICATIONS

Model 8400VD/VDW is basically the same as the existing Model 8400D/DW except the following.

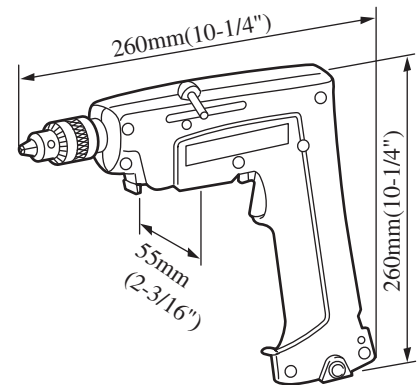

	8400VD/VDW	8400D/DW
Tool speed	Variable	Single
Feedback circuit	Yes	No
Electric brake	Yes	No

Model 8400VD is sold without a battery cartridge and a fast charger.

Model 8400VDW includes a battery cartridge 9000 and a fast charger DC9700.

▶ Specifications

DC Magnet Motor 9.6V
Capacities

Steel/Concrete	10mm (3/8")
Wood	12mm (1/2")
Wood Screw	3.8mm (5/32")x20mm (13/16")
Max. Tightening Torque	50 Kg. cm (3.6ft. lbs)
No Load Speed	0 - 900 R/min.
Blows per Minute	0 -10,000
Net Weight	1.7 Kg (3.7 lbs) including battery cartridge 9000

▶ Standard equipment

Fast Charger DC9700, Battery Cartridge 9000, Chuck Key S10, Plastic Carrying Case (8400VDW only)

▶ Optional accessories

Battery Cartridge 9000, Various size of Tungsten-carbide Tipped Bits, Various size of Drill Bits, Various size of Phillips Bits, Various size of Slotted Bits, Foam Polishing Pad 125, Rubber Pad Assembly, Wool Bonnet 100, Various size of Abrasive Discs, Fast Charger DC9700, DC9015, DC9112

The standard equipment for the tools shown may differ from country to country