

T ECHNICAL INFORMATION



New Tool

Models No. ▶ 8411D

Description ▶ 10mm(3/8") Cordless Hammer Drill

CONCEPTION AND MAIN APPLICATIONS

This is a 12 V powerful Cordless Hammer Drill which performs faster and more efficient drilling or hammer drilling. It is equipped with a new type keyless drill chuck which has a preventive mechanism against loosening. Model 8411D is sold with battery cartridge 1200 but without fast charger. Model 8411DW includes battery cartridge 1200 and fast charger DC1200.

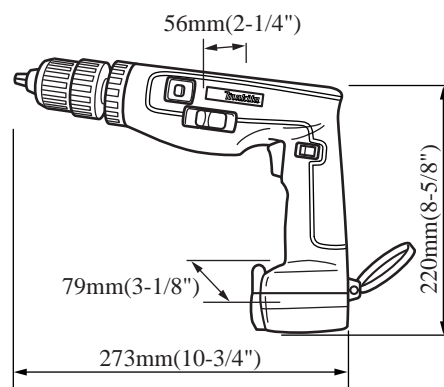

► Specifications

DC Magnet Motor (12V)

No Load Speed	High	0-1,150 R /min.
	Low	0-370 R /min.
Blows per Minute	At High Speed	0-12,700
	At Low Speed	0-4,100
Capacities	Steel/Concrete	10mm(3/8")
	Wood	21mm(13/16")
	Wood Screw	6.4mm(1/4")x 55mm(2-3/16")
Max. Fastening Torque	At High Speed	About 65Kg . cm (4.7 ft. lbs)
	At Low Speed	About 210Kg . cm (15.2 ft. lbs)
Net Weight		1.87 Kg (4.2 lbs)

► Standard equipment

Battery Cartridge 1200, Fast Charger DC1200 (8411DW only), Plastic Carrying Case (8411DW only)

► Optional accessories

Battery Cartridge 1200, Various size of Tungsten-carbide Tipped Bits, Various size of Drill Bits, Various size of Phillips Bits, Various size of Slotted Bits, Foam Polishing Pad 125, Rubber Pad Assembly, Wool Bonnet 100, Fast Charger DC1200