

# T ECHNICAL INFORMATION



New Tool

**Models No.** ▶ 8412D

**Description** ▶ Cordless Percussion-Driver Drill

## CONCEPTION AND MAIN APPLICATIONS

Model 8412DH/DWH can be used in three way: as a hammer drill, drill or driver.

Electronic control allows constant speed and high power at any load.

Model 8412DH is sold with a battery cartridge 1201 but without a fast charger.

Model 8412DWH includes a battery cartridge 1201 and a fast charger DC1201.

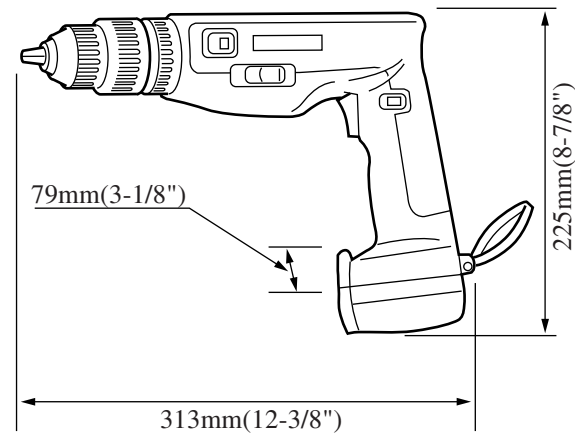

### ► Specifications

<b>DC Magnet Motor</b>		12V
<b>No Load Speed</b>	<b>High</b>	0-1150 R/min.
	<b>Low</b>	0-370 R/min.
<b>Blows per Minute</b>	<b>High</b>	0-12700
	<b>Low</b>	0-4100
<b>Capacities</b>	<b>Steel</b>	13mm (1/2")
	<b>Concrete</b>	10mm (3/8")
	<b>wood</b>	24mm (15/16")
	<b>Wood Screw</b>	6.4mm x 55mm (1/4" x 2-3/16")
	<b>Machine Screw/Nut</b>	M8 (5/16")
<b>Net weight</b>		2.2kg (4.9lbs)

### ► Standard equipment

Fast Charger DC1201 (8412DWH only), Battery Cartridge 1201, Phillips Bit, Plastic Carrying Case (8412DWH only).

### ► Optional accessories

Drill Bit 1.5, 2, 3, 4, 5, 6 (for steel), Drill Bit 9, 12, 15 (for wood), Phillips Bit 1-65, 2-45, 2-65, 2-82, 2-110, 2-150, 2-250, 3-45, 3-65, 3-110, Slotted Bit 5-45, 5-82, 6-70, 6.35-45, 8-45, 8-70, Tungsten-carbide Tipped Bit 5-70, 6.5-80, 7.5-90, 8-120, 8.5-180, 9.5-120, Foam Polishing Pad 125, Rubber Pad Assembly, Wool Bonnet 100, Battery Cartridge 1200, 1201, Fast Charger DC1201, Blow-out Bulb 54