

# T ECHNICAL INFORMATION



New Tool

**Models No.** ▶ 8450

**Description** ▶ 15mm Hammer Drills

## CONCEPTION AND MAIN APPLICATIONS

These hammer drills are newly designed versions of the existing model HP1500 series. Its brief benefit is addition of hook.

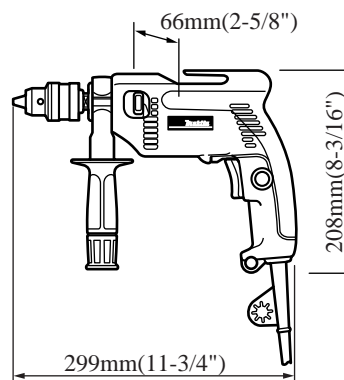

| Model | Variable speed | Reversing | Drill chuck | Plastic carrying case |
|-------|----------------|-----------|-------------|-----------------------|
| 8450  | Yes            | Yes       | Keyed       | No                    |
| 8450K | Yes            | Yes       | Keyed       | Yes                   |
| 8451  | Yes            | Yes       | Keyless     | No                    |
| 8451K | Yes            | Yes       | Keyless     | Yes                   |
| 8452  | No             | No        | Keyed       | No                    |

### ► Specifications

| Voltage (V) | Current (A) | Cycle (Hz) | Continuous Rating (W) |        | Max. Output(W) |
|-------------|-------------|------------|-----------------------|--------|----------------|
|             |             |            | Input                 | Output |                |
| 100         | 5.9         | 50/60      | 560                   | 270    | 360            |
| 115         | 5.1         | 50/60      | 560                   | 270    | 430            |
| 220         | 2.6         | 50/60      | 560                   | 290    | 480            |
| 220/230     | 2.7         | 50/60      | 560                   | 290    | 480            |
| 230         | 2.6         | 50/60      | 560                   | 290    | 480            |
| 240         | 2.5         | 50/60      | 560                   | 290    | 480            |

|                                |                           |                        |            |
|--------------------------------|---------------------------|------------------------|------------|
| <b>No load speed</b>           | 8450/8450K/<br>8451/8451K | Rotations/min.         | 0-2800rpm  |
|                                |                           | Blows/min.             | 0-44800bpm |
|                                | 8452                      | Rotations/min.         | 2800rpm    |
|                                |                           | Blows/min.             | 44800rpm   |
| <b>Chuck capacities</b>        | 8450/8450K/8452           | 1.5mm-13mm(1/16"-1/2") |            |
|                                | 8451/8451K                | 2mm-13mm(3/64"-1/2")   |            |
| <b>Max.drilling capacities</b> | Concrete                  | 15mm(9/16")            |            |
|                                | Steel                     | 13mm(1/2")             |            |
|                                | Wood                      | 25mm(1")               |            |
| <b>Net weight</b>              | 1.7Kg(3.7lbs)             |                        |            |
| <b>Cord length</b>             | 2.0m(6.6ft)               |                        |            |

### ► Standard equipment

Chuck Key S13-----1 pc. (8450,8450K, 8452 only)

Depth Gauge-----1 pc.

Plastic Carrying Case-----1 pc. (8450K, 8451K only)

### ► Optional accessories

Keyless Drill Chuck Set Drill Chuck S13

The standard equipment for the tools shown may differ from country to country.

## ► Repair

Same as HP1500 other than housing. See the new product technical information BL-2324.(Note that the electrical material is excluded.)

## ► Circuit drawing

8450, 8451 8450K 8451K

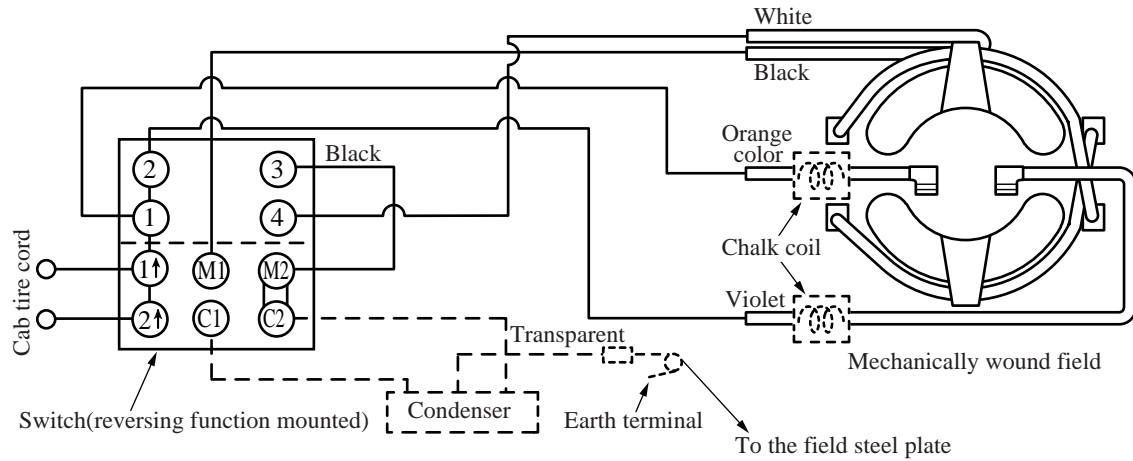

8452

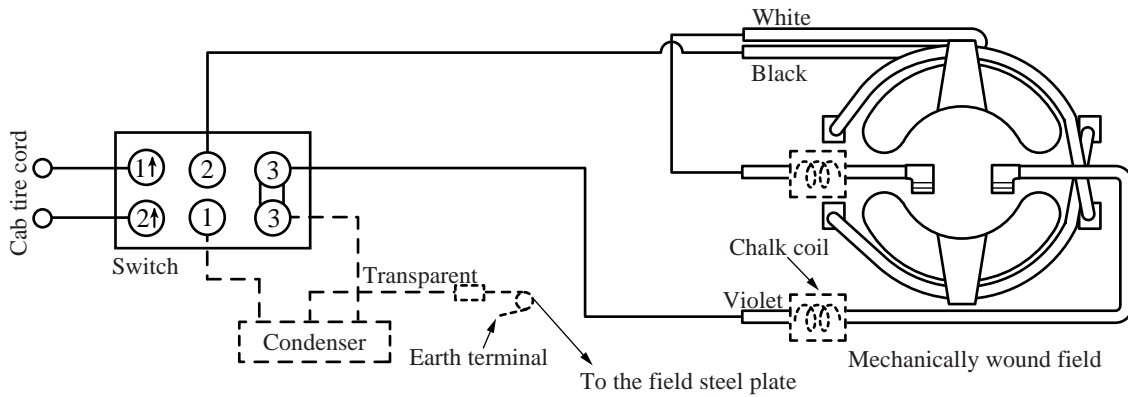

The condenser is not used in some areas and the condenser with two legs(without lead wire) is used in other areas.  
The chalk coil(with lead wire) is not used in some areas.