

# TECHNICAL INFORMATION



New Tool

Models No. ▶ 9027

Description ▶ 180 mm (7") Disc Grinder

## CONCEPTION AND MAIN APPLICATIONS

Model 9027 is 180 mm (7") version of the existing Model 9029. Models 9027F and 9027SF have a super flange. Models 9027S and 9027SF have soft start feature.

(Note) Models 9027S and 9027SF are offered to 200V - 240V areas and countries only.

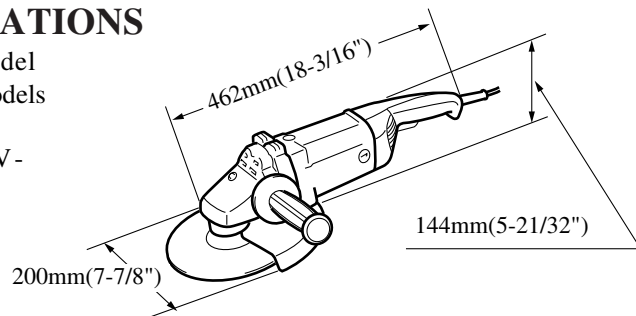

### ► Specifications

Voltage (V)	Current (A)	Cycle (Hz)	Continuous Rating (W)		Max. Output (W)
			Input	Output	
100	15.0	50/60	1,430	600	2,600
115	15.0	50/60	1,650	800	2,600
200	10.5	50/60	2,000	1,200	3,500
220	9.6	50/60	2,000	1,200	3,500
230	9.2	50/60	2,000	1,200	3,500
240	8.8	50/60	2,000	1,200	3,500

No load speed		8,500 R/min.
Capacities	Depressed Center Wheel	180mm (7")
	Wire Cup. Brush	110mm (4-3/8")
Net weight		5.4kg (11.9lbs)

### ► Standard equipment

Lock Nut Wrench 35, Grip 35

### ► Optional accessories

Depressed Center Wheel 24P, 36P, Inner Flange 47 (DIN spec. Super Flange), Inner Flange 78 (for cut-off wheel), Outer Flange 78 (for cut-off wheel), Wire Cup Brush 110, Loop Handle

The standard equipment for the tools shown may differ from country to country.