

T ECHNICAL INFORMATION



New Tool

Models No. ▶ 9031

Description ▶ 30 mm (1-3/16") Belt Sander

CONCEPTION AND MAIN APPLICATIONS

Model 9031 is an improved version of the existing Model 9030.

- * More powerful
- * Equipped with a speed adjusting dial
- * Can be connected to Makita vacuum cleaner/dust collector

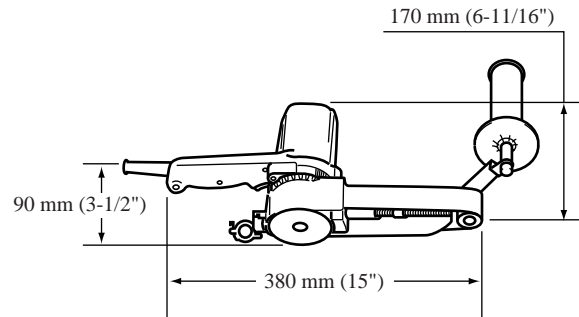

► Specifications

| Voltage (V) | Current (A) | Cycle (Hz) | Continuous Rating (W) | | Max. Output(W) |
|-------------|-------------|------------|-----------------------|--------|----------------|
| | | | Input | Output | |
| 100 | 5.8 | 50/60 | 550 | 300 | 520 |
| 115 | 5.0 | 50/60 | 550 | 300 | 520 |
| 220 | 2.6 | 50/60 | 550 | 300 | 520 |
| 230 | 2.5 | 50/60 | 550 | 300 | 520 |
| 240 | 2.4 | 50/60 | 550 | 300 | 520 |

| | |
|-------------------|--|
| Belt size | 30 mm x 533mm (1-3/16" x 21") |
| Belt speed | 200 m/min. 1,000 m/min. (660 ft/mm. - 3,300 ft/min.) |
| Net Weight | 2.1 kg (4.6 lbs) |

► Standard equipment

Abrasive belts 533-40, 60, 80, 100, 120 (AA type for wood, iron and steel)

► Optional accessories

Abrasive belts 533-40, 60, 80, 100, 120, 150, 240 (AA type for wood, iron and steel), Abrasive belts 533-40, 60, 80, 100, 120, 150 240 (CC type for stone and plastics), Hose 19

The standard equipment for the tools shown may differ form country to country