

# T ECHNICAL INFORMATION



New Tool

**Models No.** ▶ 9035

**Description** ▶ Finishing sander

## CONCEPTION AND MAIN APPLICATIONS

Develop to expand the sales market for home appliance as the sister version of the model 9035SB.

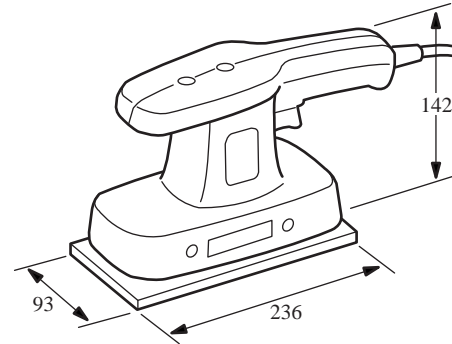

### ► Specifications

Single-phase Voltage	Current	Frequency	Consumed power
100V	2 A	50-60 Hz	160 W

No load speed	10,000 R.P.M.
Pad size	93 x 185 mm
Paper size	93 x 228 mm
Weight	1.35 kg
Cord length	2.5 m

### ► Standard equipment

Sanding paper #60, #100, #150, two pieces for each

### ► Optional accessories

Sanding paper #60, #100, #150

### ► Repair

Same as 9035SB

The standard equipment for the tools shown may differ form country to country