

T ECHNICAL INFORMATION

Models No. ▶ 9035N

Description ▶ Finishing Sander

CONCEPT AND MAIN APPLICATIONS

Model 9035N has the switching arrangement for orbital and straight movement. The orbital movement is for general finishing, and the straight movement is for grain finishing.

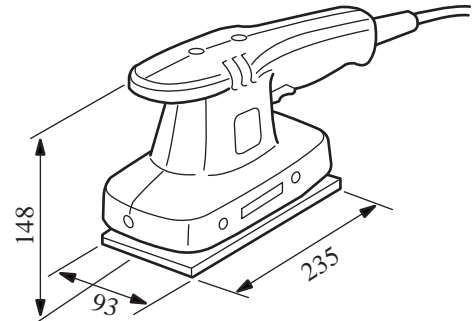

▶ Specifications

Voltage(V)	Current(A)	Cycle(Hz)	Continuous rating		Max.output(W)
			Input(W)	Output(W)	
100	1.7	50/60	130	30	40
115	1.5	50/60	130	30	40
200	0.9	50/60	130	30	40
220	0.8	50/60	130	30	40
230	0.7	50/60	130	30	40
240	0.7	50/60	130	30	40

No load speed (R.P.M.)	7000/min.
Abrasive paper size	93 x 228 mm
Pad size	93 x 185mm
Net weight	1.45 kg
Power supply cord	2.5 m

▶ Standard equipment

Sanding paper 93-60 2 sheets
Sanding paper 93-100 2 sheets
Sanding paper 93-150 2 sheets

▶ Optional accessories

Sanding paper 93-60
Sanding paper 93-10
Sanding paper 93-150

▶ Repair

1. Remove screws fixing the base at 4 points to detach the base.
2. Except the above step, follow the procedures for 9035SB and 9035.