

TECHNICAL INFORMATION



PRODUCT

P 1 / 1

Models No. ▶ 9036

Description ▶ Finishing sander

CONCEPTION AND MAIN APPLICATIONS

The new finishing sander has been launched to the market with the following features and benefits.

- * Easy to change sanding papers with large paper clamp assembled in front of the product
- * Equipped with dust extraction nozzle for connecting to MAKITA vacuum cleaner.

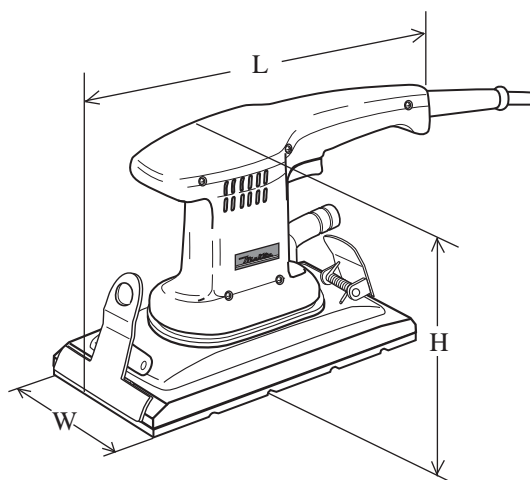

Dimensions : mm (")	
Length (L)	238 (9-3/8)
Width (W)	93 (3-5/8)
Height (H)	151 (5-15/16)

► Specification

Voltage (V)	Current (A)	Cycle (Hz)	Continuous Rating (W)		Max. Output(W)
			Input	Output	
115	1.8	50 / 60	180	90	95
200	1.1	50 / 60	180	90	95
220	1.0	50 / 60	180	90	95
230	0.9	50 / 60	180	90	95
240	0.9	50 / 60	180	90	95

Pad size : mm (")		93 (3-5/8) x 185 (7-1/4)
Paper size : mm (")		93 (3-5/8) x 228 (9)
Paper attaching system	Paper clamp	○
	Hook and loop	
Orbit per min : opm = min ⁻¹		12,000
Orbit diameter : mm (")		2.3 (3/32)
Dust extracting	by Through the pad	
	with Vacuum cleaner	○
Protection from electric shock		by double insulation
Cord length : m (")		2.0 (6.6)
Net weight : Kg (lbs)		1.4 (3.0)

► Standard equipment

* Abrasive papers 6 pcs. (grit 60 : 2 pcs. grit 80 : 2 pcs. grit 100 : 2 pcs.)

< Note > The standard equipment for the tool shown may differ from country to country.

► Optional accessories

- * Abrasive paper 93- 60
- * Abrasive paper 93- 80
- * Abrasive paper 93- 100
- * Abrasive paper 93- 150
- * Punch plate
- * Hose complete 19 - 2.5