

For Models ▶ 9077, 9077S, 9077SL / 9079, 9079S

Description ▶ 180mm (7") / 230mm (9") Disc Grinders

CONCEPTION AND MAIN APPLICATIONS

The above models are the products with high durability for stone work in professional use.

The benefits are

1. Coil spring on gear section for deadening the shock by accidental wheel lock.
2. Enable to change the handle's angle without any tools for employing as a cutting machine.
3. Trouble free new soft starter.

Mod.9077S, 9079S : with soft start feature

Mod.9077, 9079 : without soft start feature

Mod.9077SL : Low speed and high torque version of Mod.9077S

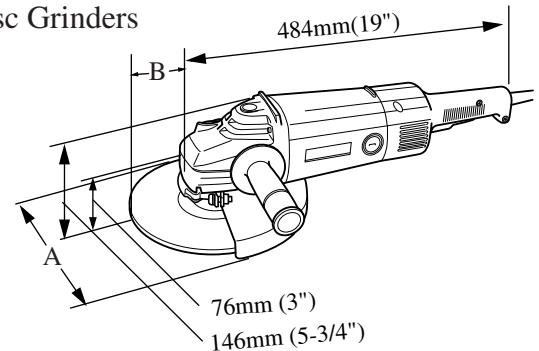

A:200mm(7-7/8") for 9077, 9077S, 9077SL
 A:250mm(9-7/8") for 9079, 9079S,
 B:43mm(1-11/16") for 9077, 9077S, 9077SL
 B:68mm(2-11/16") for 9079, 9079S,

► Specifications

Model No.	Voltage (V)	Current(A)	Cycle(Hz)	Continuous Rating(W)		Max. output(W)
				Input	Output	
9077 9077S 9079 9079S	110	15	50/60	1650	800	2600
	*110	19		2000	1100	2600
	120	15		1650	800	2600
	220	9.6		2000	1100	3300
	230	9.2		2000	1100	3300
	240	8.8		2000	1100	3300
9077SL	100	15	50/60	1430	600	2600
	120	15		1650	800	2600
	200	7.5		1430	600	2600

*110 : Great Britain

Motor		Series commutator motor (S94-50 load)		
No Load Speed	9077 (for Mexico)	8100 R/min.		
	9077, 9077S	7600 R/min.		
	9079, 9079S, 9077SL	6000 R/min.		
Depressed center wheel	9077,9077S,9077SL	Outer diameter	Inner diameter	Thickness
		180 mm 7"	22.23 mm 7/8"	6 mm 1/4"
Depressed center wheel	9079, 9079S	Outer diameter	Inner diameter	Thickness
		230 mm 9"	22.23 mm 7/8"	6 mm 1/4"

► Standard equipment

For Mod.9077, 907S, 9079, 9079S : Lock nut wrench35

For Mod.9077SL : Lock Nut Wrench 35, Depressed Center Wheel 180-36P

► Optional accesories

Descr[tions	9077, 907S,	9079, 9079S	9077SL
Inner flange 47 set (Super flange)	Yes	Yes	Yes
Depressed center wheel 180-24P	Yes		Yes
Depressed center wheel 180-36P	Yes		Yes
Depressed center wheel 230-24P		Yes	
Depressed center wheel 230-36P		Yes	
Inner flange 78 and Outer falnge 78 for cut off wheel	Yes	Yes	
Wire cup brush 110 set	Yes	Yes	Yes
Loop handle	Yes	Yes	Yes
Dust collecting wheel guard	Yes	Yes	Yes
Sanding disc 180			Yes
Diamond wheel 180 and 230	Yes (180mm)	Yes (230mm)	Yes (180mm)

► Repairing

<1> Replacement of armature and spiral bevel gear 14 (11)

- (1) Remove grinding wheel and wheel cover.
- (2) Remove brush holder cap and carbon brushes.
- (3) Remove hex socket head bolt M5x40 from gear housing. Then gear housing can be removed together with armature, from motor housing.
- (4) Remove hex socket head bolt M5x16 from gear housing. Then bearing box can be removed.
- (5) Lock armature and take off hex nut M8 with spanner from armature shaft.
- (6) Pull out armature from gear housing.

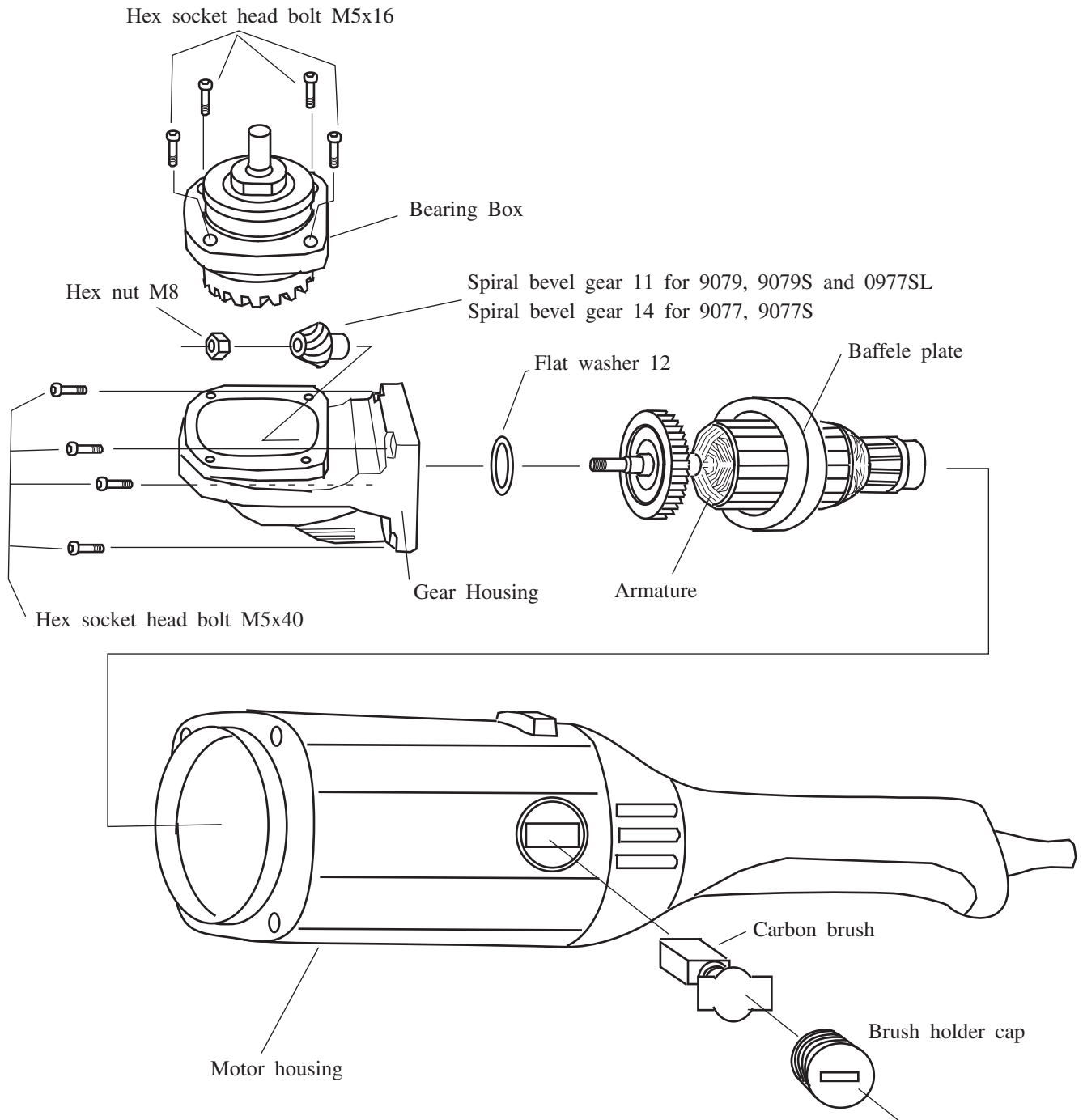

Dismounting of lock sleeve and lock springs

(7) Remove lock sleeve from spiral bevel gear 53 by turning in the direction of ↻.

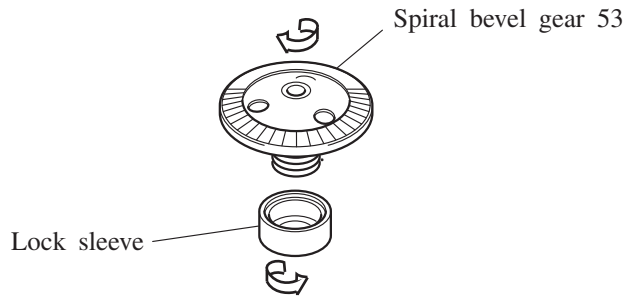

(8) Remove lock spring 25 from spiral bevel gear 53 by turning in the direction of ↻. And then lock spring 17 by turning in the direction of ↻.

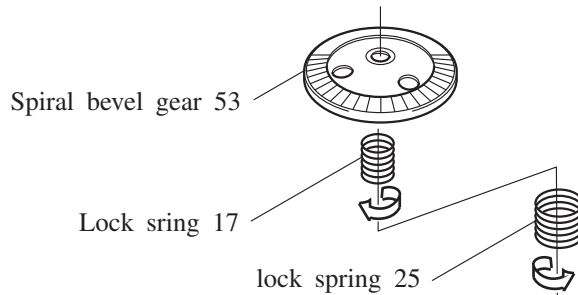

Mounting of lock sleeve and lock springs (Process after replacement of spiral bevel gear 53)

(9) Apply grease inside of lock spring 17, and outside of lock spring 25.

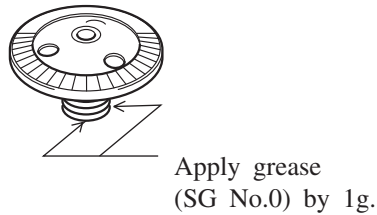

(10) Mount lock spring 17 by turning in the direction of ↻ on the spiral bevel gear 53. And then, lock spring 25 by turning in the direction of ↻ on the spiral gear 53.

(11) Mount lock sleeve by turning in the direction of ↻, on the spiral bevel gear 53 on which lock spring 17 and 25 have been mounted in the step (10).

(12) Push spiral bevel gear 53 and lock sleeve on the spindle by turning them in the direction of ↻ as far as lock sleeve will interlock with flat section of spindle. And then, put the repairing jig No.1R028 on the spiral bevel gear 53. Press the spiral bevel gear 53 with arbor press.

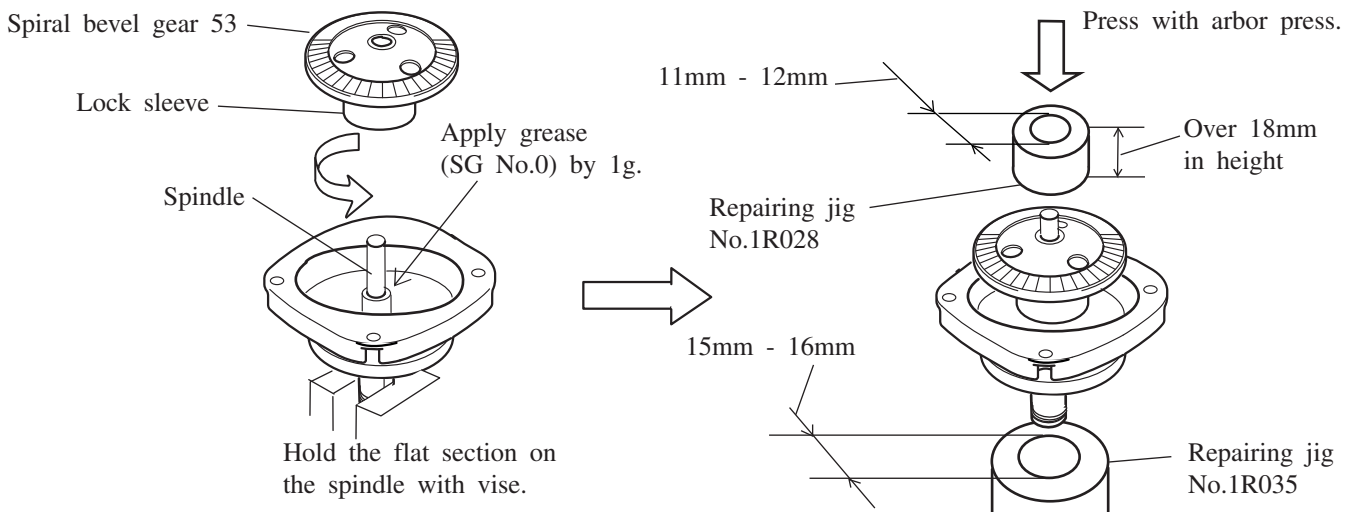

< 2 > Replacement of spiral bevel gear 53

Not only in case of damage on gear itself but also in case of damage on ball bearing, spiral bevel gear 53 has to be replaced with fresh one.

- (1) Remove grinding wheel and wheel cover.
- (2) Remove hex socket head bolt M5x16 from gear housing. Then, spiral bevel gear 53 can be removed together with bearing box, from gear housing.
- (3) Take off sleeve 10.
- (4) Take off ring spring 9 with pawl for retaining ring.
(The removed ring spring 9 has to be corrected with plyer for fitting inside the sleeve 10 again.)
- (5) Take off flat washer 10.

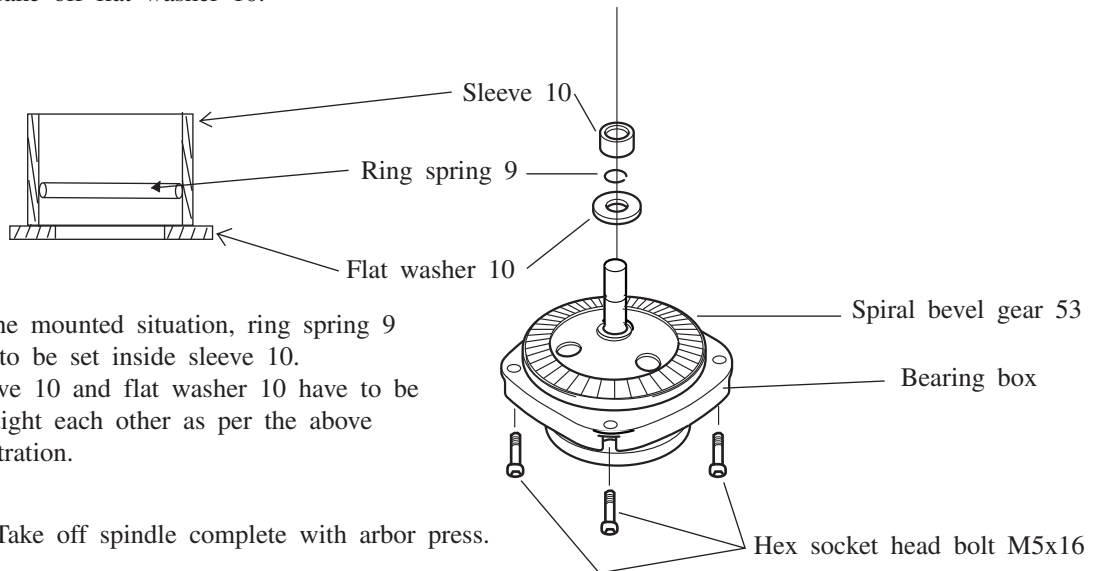

In the mounted situation, ring spring 9 has to be set inside sleeve 10. Sleeve 10 and flat washer 10 have to be set tight each other as per the above illustration.

- (6) Take off spindle complete with arbor press.

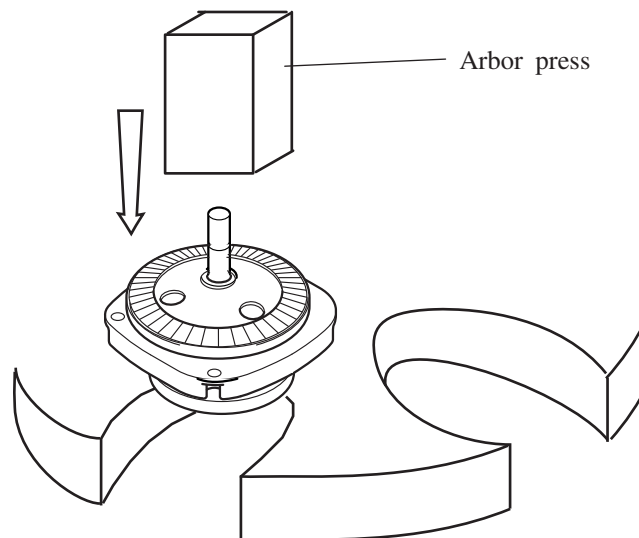

Set the bearing box with spiral bevel gear 53 and spindle on the widest U-form (width: 60mm).

< 3 > Grease

Apply the grease SG No.0 in the gear housing by 50 g.

► Remarks

The wheel cover of 5/8" can be used with this machine, if the flanged diamond wheel contacts the original wheel cover.

The parts Nos are as follows.

No.163425-0 for 180mm (7") wheel

No.163424-2 for 230mm (9") wheel

▶ Circuit diagram

Model 9077 and 9079, without soft starter

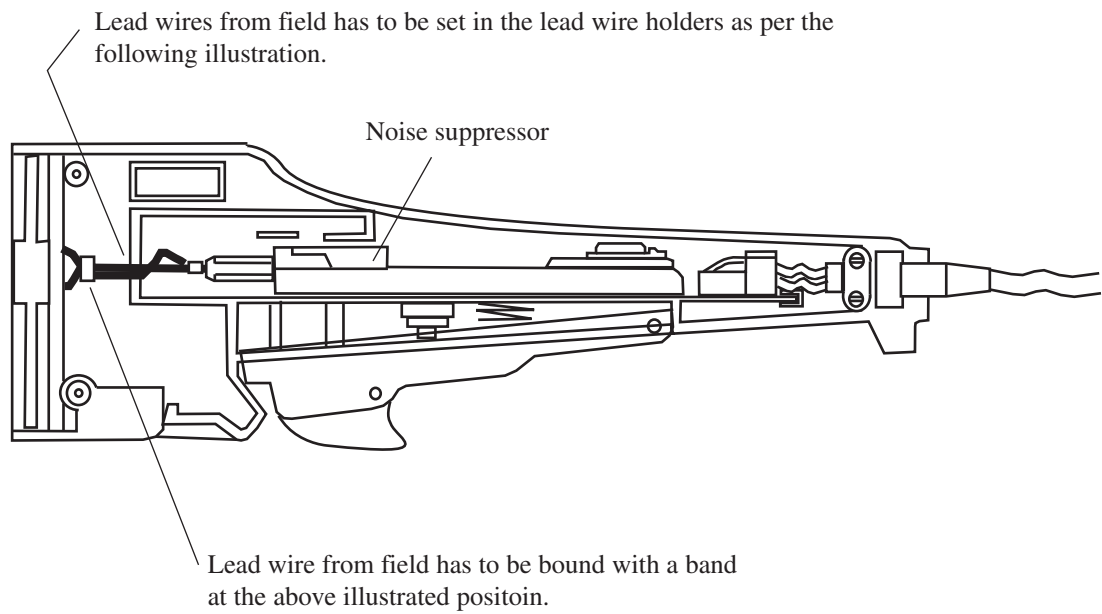
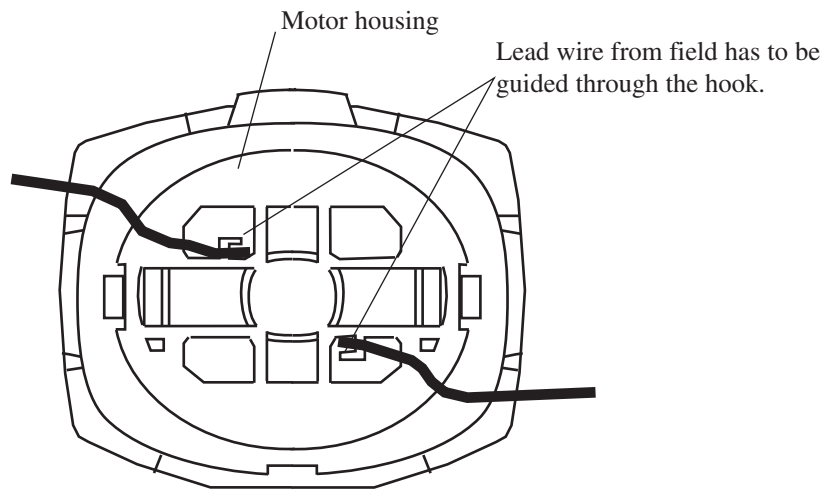
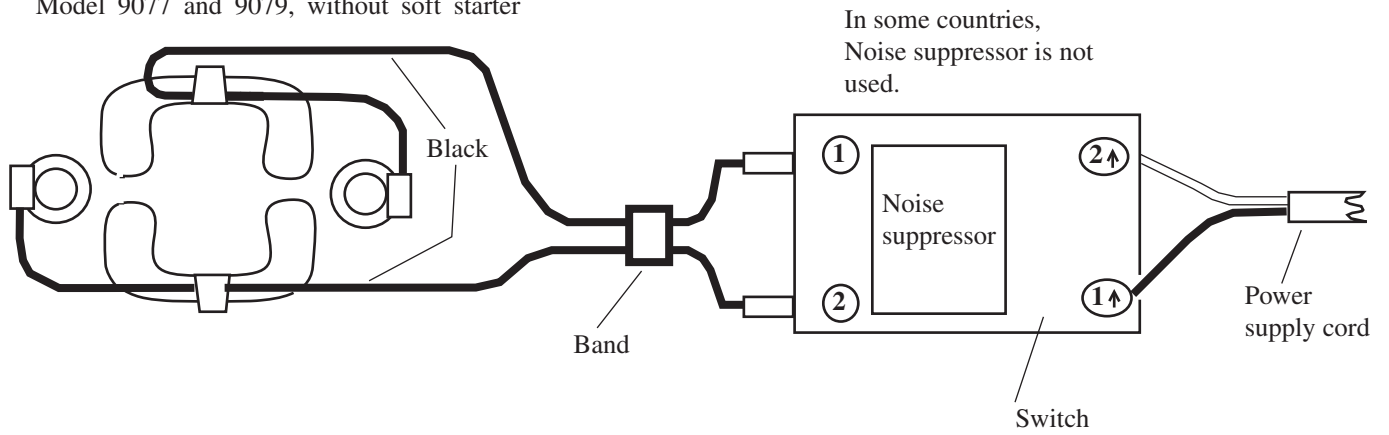

▶ Circuit diagram

Model 9077S, 9077SL and 9079S, with soft starter

In some countries,
Noise suppressor is not
used.

