

TECHNICAL INFORMATION



New Tool

Models No. ▶ 9207SPB

Description ▶ 180 mm Sander polisher

CONCEPTION AND MAIN APPLICATIONS

This machine has been for export exclusive type until now, but also selling for domestic is started. The sander and polisher can be individually used by the use of 2-speed and the double insulation structure can conform to both domestic and foreign regulation.

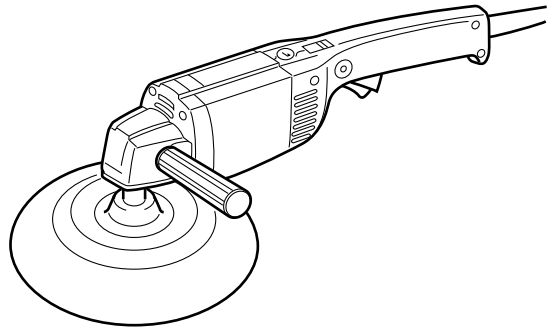

► Specifications

Voltage(V)	Current (A)	Frequency (Hz)	Continuous rating input(W)
100	6	50-60	570

No load speed	3800/2000 min.
Overall length of machine	460 mm
Weight	3.4 kg
Cord length	2.5 m

► Standard equipment

	Names	Applications	Quantity
1	Sanding disc 180-16	For grinding and sanding	2
2	Sanding disc 180-20	For grinding and sanding	2
3	Sanding disc 180-24	For grinding and sanding	2
4	Sanding disc 180-50	For grinding and sanding	2
5	Sanding disc 180-80	For grinding and sanding	2
6	Wool bonnet 180	For polishing	1
7	Lock nut wrench 28	For mounting the rubber pad	1
8	Spanner 17	For mounting the rubber pad	1

► Optional accessories

1	Sanding disc 180-30	For grinding and sanding
2	Sanding disc 180-100	For grinding and sanding
3	Sanding disc 180-120	For grinding and sanding
4	Cup wire brush 90	For grinding and sanding

The standard equipment for the tools shown may differ from country to country

► **Repair**

- (1) Replacing of ball bearing 6201LLB inside the bearing box
 - a. Disconnect the mounting screws M4x14(4 pieces) on the bearing box.
 - b. Separate the bearing box from the gear housing and disconnect the circle clip(shaft)12 mounting the spiral bevel gear to remove the spiral bevel gear from the spindle.
 - c. Use the hand press to disconnect the spindle from the bearing box, turn the bearing retainer 22-34 in left to take away it, and then replace the ball bearing 6201LLB. For assembling, proceed in the reverse orders against said procedures.

- (2) Replacing of ball bearing 6002LLB at fan side of armature
 - a. Disconnect the bearing box and then remove the gear housing from the gear housing cover.
 - b. Turn right the bearing retainer 19-33 on the gear housing cover to remove it, remove the circle clip(shaft)15 holding the ball bearing 6002LLB from the armature shaft, and then disconnect the armature from the gear housing cover to replace the ball bearing 6002LLB