

# T ECHNICAL INFORMATION



New Tool

**Models No.** ▶ 9207SPC

**Description** ▶ MAKITA 180 mm sander polisher

## CONCEPTION AND MAIN APPLICATIONS

New product 9207SPC, is grade up functionaly from 9207SPB.

Variable speed by electronic control.

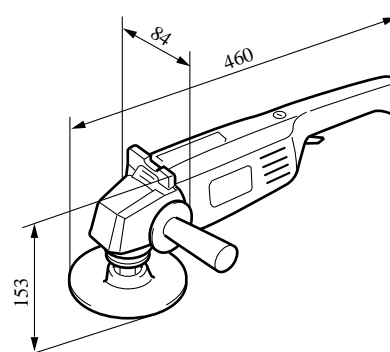

### ► Specifications

Voltage(V)	Current(A)	Frequency(Hz)	Continuous rating input		Max. output(W)
			Input(W)	output(W)	
100	6	50/60	570	390	670

<b>No load speed(R.P.M.)</b>	1500-2800
<b>Sanding disk hole diameter</b>	22.2 mm
<b>Abrasive disc</b>	180 mm
<b>Wool bonnet</b>	180 mm
<b>Net weight</b>	3.5kg
<b>Power supply cord</b>	2.5m

### ► Standard equipment

Sanding disk 180-16,180-20,180-24,180-50,180-80, Two pieces for each

Wool bonnet 180

Spanner 17

Lock nut wrench 28

The standard equipment for the tools shown may differ from country to country.

## ► Repair

### (a) Assembling of insulation washer

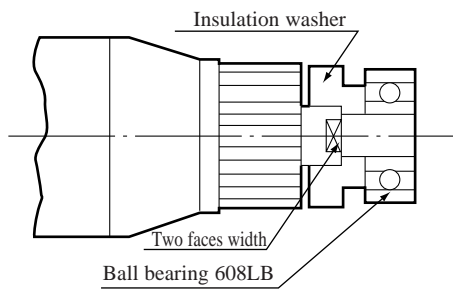

Insert the Insulation washer between the armature commutator side and the ball bearing 608LB. Since both armature shaft and the insulation washer have each two faces width for preventing from turning, be sure to fit these width each other to insert the insulation washer and then insert the ball bearing 608LB in a way that the insulation washer can be fixed using the armature shaft body and ball bearing 608LB.

Since the sensor detects the rotation speed of the armature, the magnet is housed in this insulation washer to play an important role for electronics circuit.

If the armature and the insulation washer do not turn simultaneously, the variable speed function does not run correctly. Use special caution on this point.

### (b) Fastening of the triac complete

Although the triac complete should be mounted on the field steel plate using the pan head screw M3x6, apply a little amount of screw lock for preventing loosening on the pan head screw before fastening.

### (c) Engaging adjustment of spiral bevel gear 44

If the gear noise has been increased due to the replacement of gear or gear housing, insert the appropriate quantity of shim (common for 3411327, #9207SPB) between the gear housing and bearing box.