

T ECHNICAL INFORMATION

Makita

New Tool

Models No. ▶ 9402

Description ▶ 100mm(4") Belt sander

CONCEPTION AND MAIN APPLICATIONS

This new Belt sander has been developed from 9401 into Electric two-speed function.

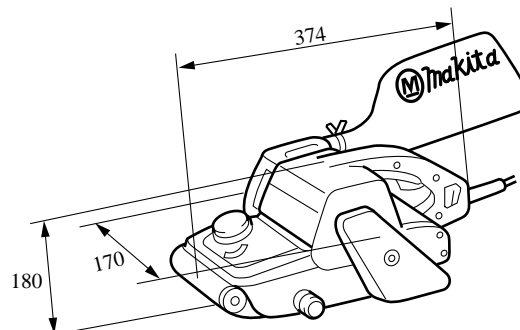

▶ Specifications

Voltage(V)	Current(A)	Frequency(Hz)	Consumed power(W)
100 V	12 A	50-60 Hz	1140 W

Belt speed	(H) 350 m/min. (L) 300m/min.
Belt size	100 x 610 mm
Weight	7.3 kg
Cord Length	5 m

▶ Standard equipment

- Step
- Carbon plate
- Each type of sanding belt

▶ Optional accessories

- Steel plate :
- Each type of sanding belt(5 pieces in one set)

▶ Repair

Although same as #9401, the lead wire inside the handle has been increased due to the installation of two speed switch. Accordingly use care that the lead wires are not locked together in assembling the handle cover.

The standard equipment for the tools shown may differ form country to country