

TECHNICAL INFORMATION

Makita

New Tool

Models No. ▶ 9503BH

Description ▶ MAKITA 115mm Disc Grinder

CONCEPTION AND MAIN APPLICATIONS

Based on the 9503B, the 115mm Offset grindstone is installed on this machine.

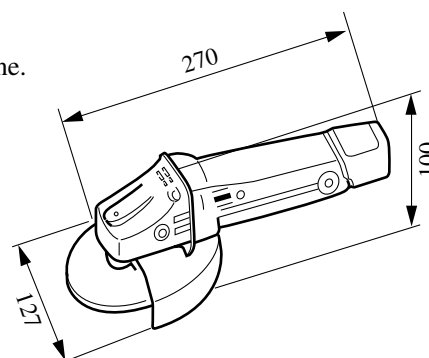

▶ Specifications

Voltage (V)	Current (A)	Cycle (Hz)	Continuous Rating (W)		Max. Output(W)
			Input	Output	
100	6.3	50/60	560	350	570

No load speed per minute	10000/min
Offset grindstone	115 in outer dia x 6 in thickness x 22 in inner dia
Net weight	2.2kg
Power supply cord	2.5m

▶ Standard equipment

Offset grindstone 115-36 (mounted on the body)
Lock nut wrench 20

▶ Optional accessories

Offset grindstone 115-24
Grip 32
Lock nut wrench 28
Wire cup brush 75 (M10 x 1.5)
Wire cup brush 85 (M10 x 1.5)
Lock nut (for Sanding disk)
Rubber pad 76 or 100
Standard disk 100 or 115-24, 30,50,80,120,100-100

The standard equipment for the tools shown may differ from country to country.