

# T ECHNICAL INFORMATION

**Makita**

New Tool

**Models No.** ▶ 9505BH

**Description** ▶ Makita 125mm disc grinder

## CONCEPTION AND MAIN APPLICATIONS

The product is 9503B mounted with a 125 mm offset sanding wheel and is only for export.

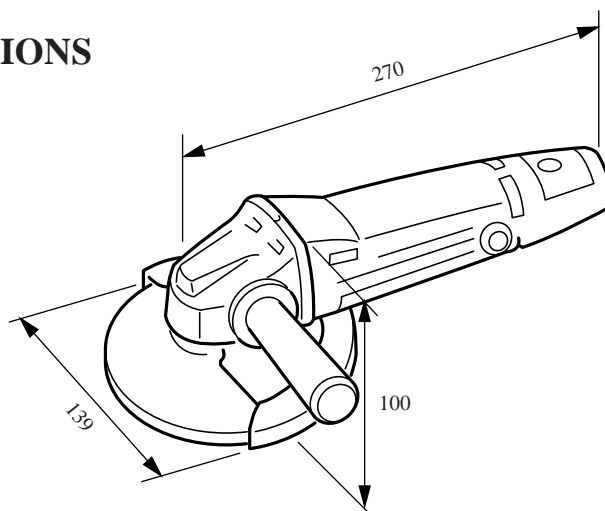

### ▶ Specifications

Voltage(V)	Current(A)	Frequency(Hz)	Consumed power(W)	Rated output(W)	Max. output(W)
100	6	50-60	560	350	570
115	5.1	50-60	560	350	570
200	3	50-60	560	350	570
220	2.7	50-60	560	350	570
230	2.6	50-60	560	350	570
240	2.5	50-60	560	350	570

<b>No load speed(/min.)</b>	10,000/min
<b>Offset sanding wheel</b>	125 in outer dia. x 6 in thickness x 22 inner dia.
<b>Weight(kg)</b>	1.6kg
<b>Cord length(m)</b>	2.5m

### ▶ Standard equipment

Offset grinding wheel 125-24  
Lock nut wrench 28

### ▶ Optional accessories

Offset grinding wheel 125-36  
Rubber pad 115  
Lock nut 16-48 (to fasten the sanding disc.)  
Sanding disc 125-24, 30, 50, 80, & 120,  
Wire brush 90 (M16x2)