

# T ECHNICAL INFORMATION



New Tool

**Models No.** ▶ 9521NB

**Description** ▶ 115 mm(4-1/2") Angle Grinder

## CONCEPTION AND MAIN APPLICATIONS

115 mm(4-1/2") version of Model 9520NB.

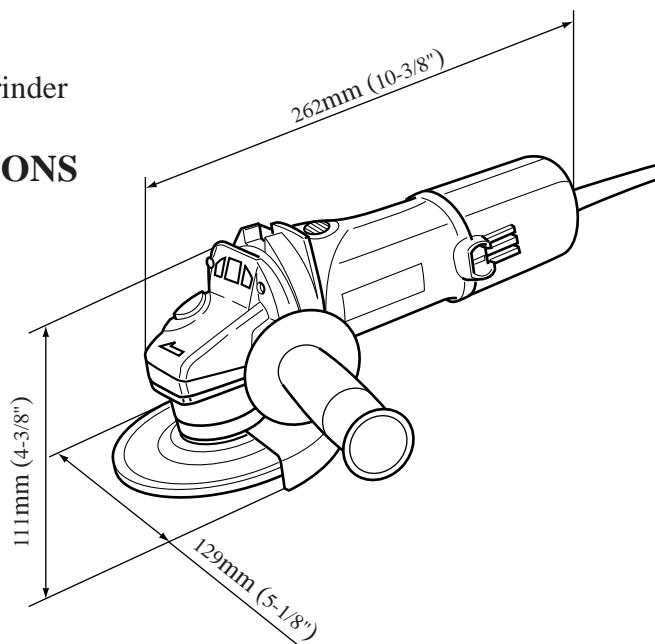

### ► Specifications

Voltage (V)	Current (A)	Cycle (Hz)	Continuous Rating (W)		Max. Output(W)
			Input	Output	
100	7.0	50/60	670	380	700
115	6.1	50/60	670	380	700
200	3.5	50/60	670	380	700
220	3.2	50/60	670	380	700
230	3.0	50/60	670	380	700
240	2.9	50/60	670	380	700

Max. capacities( dia.)	Depressed center wheel	115mm(4-1/2")
	Diamond wheel	115mm(4-1/2")
	Abrasive disc	115mm(4-1/2")
No load speed	12,000R/min.	
Net weight	1.3Kg(2.9lbs)	

### ► Standard equipment

Depressed center wheel 115-36, Lock nut wrench 35, Grip 36

### ► Optional accessories

Depressed center wheel 115-36, Rubber pad 100, Lock nut 14-48, Abrasive disc 115-24, 115-30, 115-50, 115-80, 115-120, Inner flange 47 (Super flange)