

T ECHNICAL INFORMATION

Makita

New Tool

Models No. ▶ 9522NB

Description ▶ 125mm (5") Angle Grinder

CONCEPTION AND MAIN APPLICATIONS

125 mm (5") version of Model9520NB.

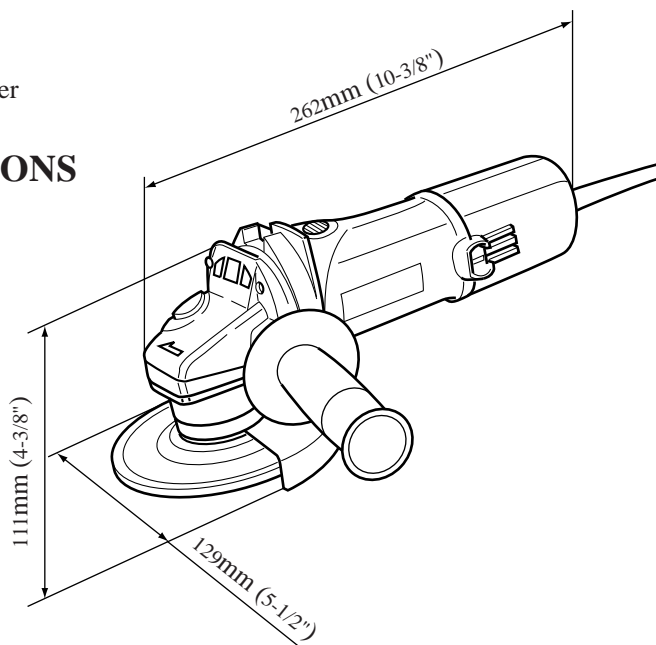

► Specifications

Voltage (V)	Current (A)	Cycle (Hz)	Continuous Rating (W)		Max. Output(W)
			Input	Output	
100	7.0	50/60	670	380	700
115	6.1	50/60	670	380	700
200	3.5	50/60	670	380	700
220	3.2	50/60	670	380	700
230	3.5	50/60	670	380	700
240	2.9	50/60	670	380	700

Max. capacities(dia.)	Depressed center wheel	125mm(5")
	Diamond wheel	125mm(5")
	Abrasive disc	125mm(5")
No load speed	12,000R/min.	
Net weight	1.3Kg(2.9lbs)	

► Standard equipment

Depressed center wheel 125-24, lock nut wrench 35,Grip 36

► Optional accessories

Depressed center wheel 125-24, Rubber pad 115, Lock nut 14-48, Abrasive disc 125-24, 125-30, 125-50, 125-80, 125-120, Inner flange 47 (Super flange)