

# T ECHNICAL INFORMATION



New Tool

**Models No.** ▶ 9524NB

**Description** ▶ 115mm Angle Grinder

## CONCEPTION AND MAIN APPLICATIONS

Model 9524NB is the angle grinder designed for accepting 115mm wheel on the basis of Model 9523NB and its brief benefits are;

- \*Slimmer body loaded with more durable new motor (type S55)
- \*Labyrinth structure seals out dust from ball bearings
- \*Comfortable slide switch

This model is manufactured in MCC.

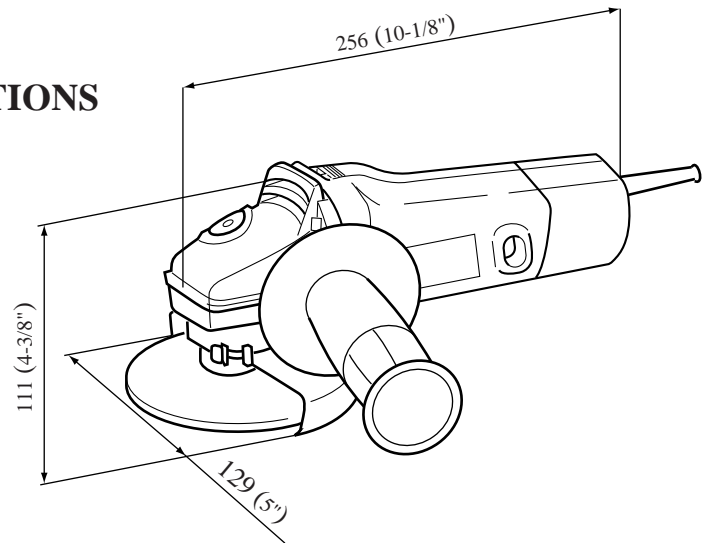

### ► Specifications

Voltage (V)	Current (A)	Cycle (Hz)	Continuous Rating (W)		Max. Output(W)
			Input	Output	
100	5.7	50/60	540	300	630
115	5.0	50/60	540	300	630
200	2.9	50/60	540	300	630
220	2.6	50/60	540	300	630
230	2.5	50/60	540	300	630
240	2.4	50/60	540	300	630

<b>Max. capacity : Depressed center wheel</b>	115(4-1/2")x22. 3(7/8")x6(1/4")
<b>No Load Speed</b>	11000R/min.
<b>Net Weight</b>	1.4kg (3.1 lbs)

### ► Standard equipment

- Lock nut wrench 35
- Depressed center wheel 115-36
- Grip 36 complete

### ► Optional accessories

- Depressed center wheel 115-36    Rubber Pad 100    Lock Nut 14-48
- Abrasive discs 115-24, 30, 50, 80, 100,120
- Inner flange 47 assembly (Super flange)

The standard equipment for the tools shown may differ form country to country.