

**For Models** ▶ 9527NB

**Description** ▶ 115mm Angle Grinder

## CONCEPTION AND MAIN APPLICATIONS

Model 9527NB is the 125mm and slide switch version of the new 100/115/125mm angle grinder series and designed for professional users.

Its brief benefits are;

\*Labyrinth structure seals out the grinded dust from ball bearings

\*Slim body loaded with durable new motor (type S55)

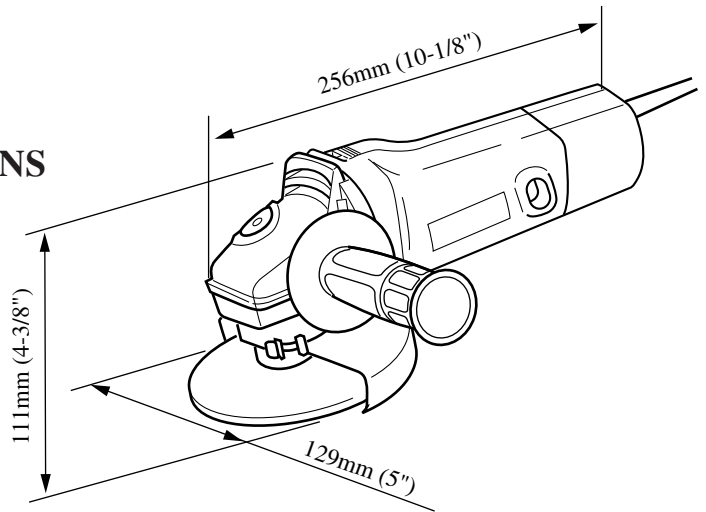

### ► Specifications

Voltage(V)	Current(A)	Cycle(Hz)	Continuous Rating(W)		Max. Output(W)
			Input	Output	
100	7.9	50/60	750	420	850
115	6.9	50/60	750	420	850
200	4	50/60	750	420	850
220	3.6	50/60	750	420	850
230	3.4	50/60	750	420	850
240	3.3	50/60	750	420	850

<b>No Load Speed</b>		11000(rpm)		
	U.S.A.	10000(rpm)		
<b>Net Weight</b>		1.4kg (3.1lbs)		
<b>Cord Length</b>		2.5m(8.2ft)		
<b>Size of depressed center wheel</b>		115(4-1/2")	X 22.23(7/8")	X 6(1/4")
		Outer diameter	Arbor diameter	Thickness

### ► Standard equipment

Lock Nut Wrench 35(Din-type).....1  
 Grip 36 Complete.....1  
 Depressed Center Wheel 115-36.....1

### ► Optional accessories

Depressed Center Wheel 115-36(5pcs./pk)  
 Rubber Pad 100  
 Lock Nut 14-48  
 Abrasive Disc 115-24, 30, 50, 80, 120  
 Inner Flange 47 Assembly(Din-type, Super Flange)  
 Diamond Wheel  
 Cut-off Wheel

### ► Repair

Corresponding to 9526NB

The Standard equipment for the tools shown may differ from country to country.