

**For Models** ▶ 9528NB

**Description** ▶ 125mm Angle Grinder

## CONCEPTION AND MAIN APPLICATIONS

Model 9528NB is the 125mm and slide switch version of the new 100/115/125mm angle grinder series and designed for professional users.

Its brief benefits are;

\*Labyrinth structure seals out the grinded dust from ball bearings

\*Slim body loaded with durable new motor (type S55)

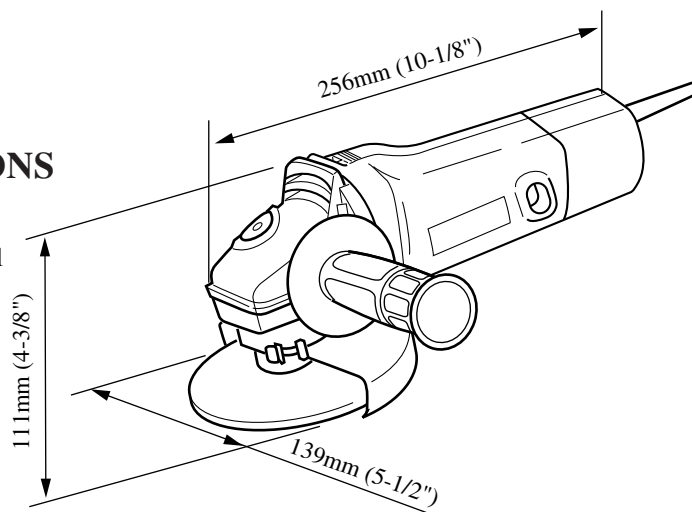

## ▶ Specifications

Voltage(V)	Current(A)	Cycle(Hz)	Continuous Rating(W)		Max. Output(W)
			Input	Output	
100	7.9	50/60	750	420	850
115	6.9	50/60	750	420	850
200	4	50/60	750	420	850
220	3.6	50/60	750	420	850
230	3.4	50/60	750	420	850
240	3.3	50/60	750	420	850

<b>No Load Speed</b>		11000(rpm)	
	U.S.A.	10000(rpm)	
<b>Net Weight</b>		1.4kg (3.1lbs)	
<b>Cord Length</b>		2.5m(8.2ft)	
<b>Size of depressed center wheel</b>	125(5")	X 22.23(7/8")	X 6(1/4")
	Outer diameter	Arbor diameter	Thickness

## ▶ Standard equipment

- Lock Nut Wrench 35(Din-type).....1
- Grip 36 Complete.....1
- Depressed Center Wheel 125-36.....1

## ▶ Optional accessories

- Depressed Center Wheel 125-36(5pcs./pk)
- Rubber Pad 115
- Lock Nut 14-48
- Abrasive Disc 125-24, 30, 50, 80, 120
- Super Flange(Din-type)
- Diamond Wheel
- Cut-off Wheel

## ▶ Repair

Corresponding to 9526NB

The Standard equipment for the tools shown may differ from country to country.