

TECHNICAL INFORMATION



PRODUCT

P 1/8

Models No. ▶ 9556HN, 9557HN, 9558HN

Description ▶ Angle Grinders 100mm (4"), 115mm (4-1/2"), 125mm (5")

CONCEPT AND MAIN APPLICATIONS

These angle grinders have been developed as sister models of 9556NB series.

Features machined bevel gears more durable than sintered bevel gears used for 9556NB series models.

9556HN is also available with plastic carrying case as Model 9556HNC.

9557HN is also available with plastic carrying case or steel carrying case as Model 9557HNC.

9558HN is also available with steel carrying case as Model 9558HNC.

AC/DC switch is used for the tools for USA and other North American countries.

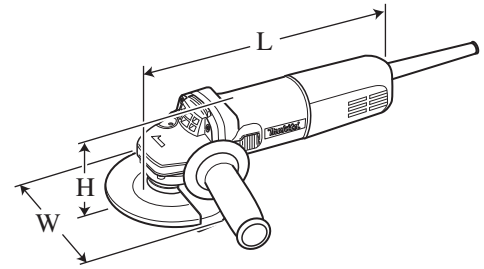

| Dimensions: mm (") | | | |
|--------------------|---------------|---------------|---------------|
| Model No. | 9556HN | 9557HN | 9558HN |
| Length (L) | 271 (10-5/8) | | |
| Width (W) | 118 (4-5/8) | 129 (5-1/8) | 139 (5-1/2) |
| Height (H) | 97 (3-13/16) | | |

Specification

| Voltage (V) | Current (A) | Cycle (Hz) | Continuous Rating (W) | | Max. Output (W) |
|-------------|-------------|------------|-----------------------|--------|-----------------|
| | | | Input | Output | |
| 110 | 8.0 | 50/60 | 840 | 500 | 1,000 |
| 120 | 7.5 | 50/60 | 840 | 500 | 1,000 |
| 220 | 4.0 | 50/60 | 840 | 500 | 1,000 |
| 230 | 3.8 | 50/60 | 840 | 500 | 1,000 |
| 240 | 3.7 | 50/60 | 840 | 500 | 1,000 |

| Specification | | Model No. | 9556HN | 9557HN | 9558HN |
|-----------------------------------|------------------------|-----------|---|---------------|---------------|
| Capacity: mm (") | Depressed center wheel | | 100 (4) | 115 (4-1/2) | 125 (5) |
| | Wire cup brush | | 75 (3) | 90 (3-1/2) | 90 (3-1/2) |
| | Abrasive disc | | 100 (4) | 115 (4-1/2) | 125 (5) |
| No load speed*1: min.-1 = rpm | | | 11,000 | | |
| Protection against electric shock | | | Double insulation | | |
| Power supply cord: m (ft) | | | Australia, New Zealand: 2.0 (6.6), Other countries: 2.5 (8.2) | | |
| Net weight*2: kg (lbs) | | | 1.9 (4.2) | 2.0 (4.4) | 2.1 (4.6) |

*1 North America: 10,000

*2 Weight according to EPTA-Procedure 01/2003

Standard equipment

| 9556HN | 9557HN | 9558HN |
|--|--------------------------------------|--------------------------------------|
| Depressed center wheel 100-36 1 | Depressed center wheel 115-36 1 | Depressed center wheel 125-36 1 |
| Lock nut wrench 20 1 | Lock nut wrench 28 1 | Lock nut wrench 35 1 |
| Grip 36 complete 1 | Grip 36 complete 1 | Grip 36 complete 1 |
| Plastic or steel carrying case 1 (for 9556HNC , 9557HNC , 9558HNC only) | | |

Note: The standard equipment for the tool shown above may vary by country.

Optional accessories

Wheel covers, Depressed center wheels, Abrasive discs, Rubber pads (for abrasive discs), Sanding lock nuts, Cut-off wheels, Super flanges (for **9557HN**, **9558HN** only), Wire cup brushes, Wire bevel brush (for **9556HN** only), Dust collecting wheel guards

► Repair

CAUTION: Disconnect the machine and remove the wheel for safety before repair/maintenance!

[1] NECESSARY REPAIRING TOOLS

| Code No. | Description | Use for |
|----------|--|---|
| 1R028 | Bearing Setting Pipe | Installing Retaining ring S-12 |
| 1R045 | Gear Extractor (large) | Removing Spindle from Bearing box |
| 1R346 | Center Attachment for 1R045 | Removing Spindle from Bearing box (for modular use with 1R045) |
| 1R269 | Bearing Extractor | Removing Ball bearings |
| 1R291 | Retaining Ring S and R Pliers | Removing Retaining ring S-12 and R-32 |
| 1R343 | Retaining Ring Setting Jig | Installing Retaining ring S-12 |
| 1R----- | Bearing Setting Plate (of proper size) | Assembling Ball bearing 629LLB and Armature to Gear housing cover |

[2] LUBRICATION AND SEALING

Put 7g of Makita Grease N. No.1 into the gear room of Gear housing.

[3] DISASSEMBLY/ASSEMBLY

[3] -1. Armature and Spiral Bevel Gear 10

DISASSEMBLING

- 1) Remove 4x18 Tapping screw and separate Rear cover from Motor housing. Then remove Carbon brushes. (**Fig. 1**)
- 2) Unscrew four 4x30 Tapping screws and remove the assembled unit of Gear housing and Armature. (**Fig. 1**)

Fig. 1

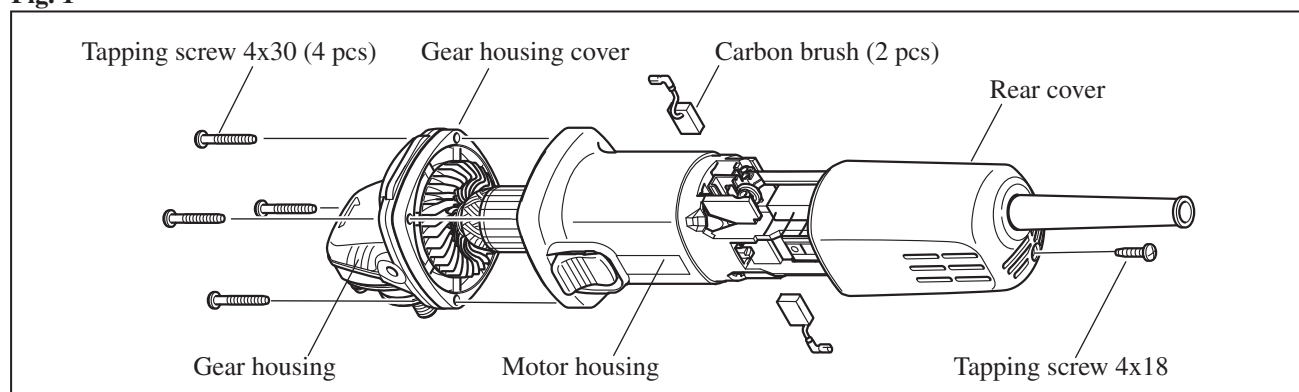

- 3) Pull off the assembled unit of Armature and Gear housing cover from Gear housing.
- 4) Grip Armature securely by gloved hand, then remove Hex nut M6 by turning counterclockwise with wrench 10. (**Fig. 2**)
- 5) Remove Spiral bevel gear 10 by gloved hand. (**Fig. 3**)
 - If the gear cannot be removed by hand, do the following steps;
 1. Spray some lubricant to the contact portion of the gear and Armature shaft.
 2. Wrap the gear with wasted cloth for protection of the gear threads, then turn the gear using water pump pliers.
- 6) Remove Armature from Gear housing cover with Gear Extractor, large (No.1R045).

Fig. 2

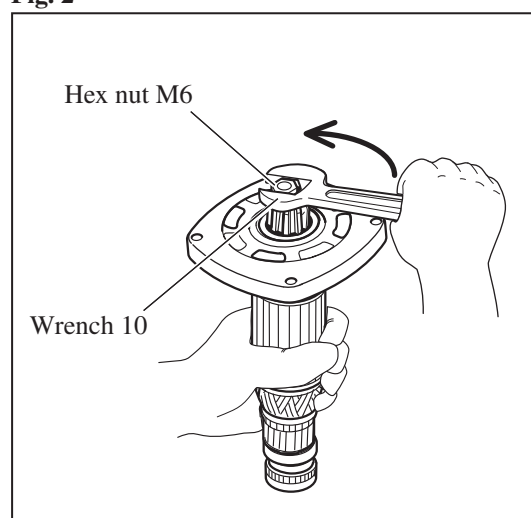
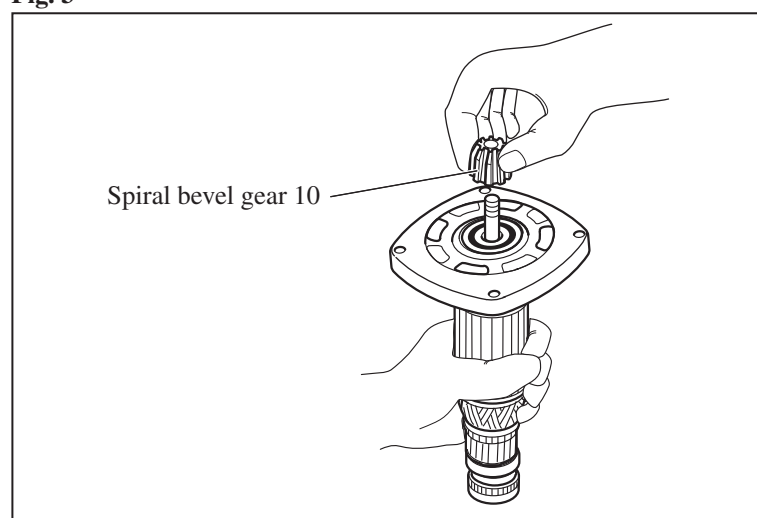

Fig. 3



► Repair

[3] -1. Armature and Small Spiral Bevel Gear (cont.)

ASSEMBLING

Do the reverse of the disassembling steps.

Note: Use arbor press and Bearing Setting Plate (of proper size) when fitting Ball bearing 629LLB in Gear housing cover. (**Fig. 4**)

Important: Assemble Gear housing to Motor housing so that Switch lever can be operated with right thumb as illustrated in **Fig. 5**.

Fig. 4

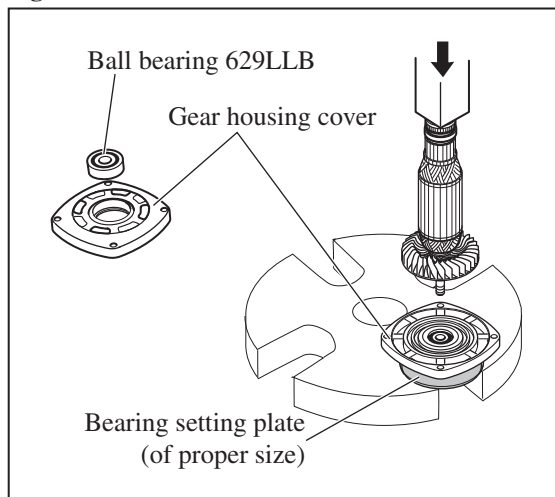
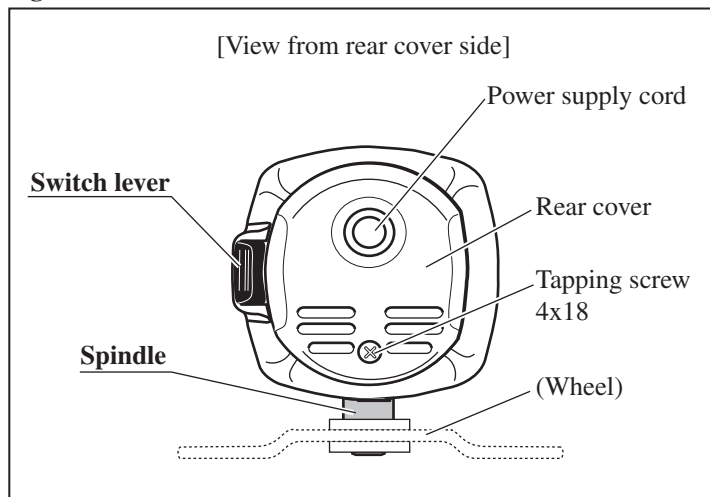

Fig. 5



[3] -2. Spiral Bevel Gear 37 and Ball Bearing 6201DDW

DISASSEMBLING

- 1) Remove Bearing box from Gear housing by unscrewing four M4x14 Pan head screws.
- 2) Remove Retaining ring S-12 and Wave washer 12 from Spindle with Retaining Ring S and R Pliers (No.1R291).
- 3) Spiral bevel gear 37 can now be removed by hand. Then remove Woodruff key 4. (**Fig. 6**)
- 4) Remove Spindle using Gear Extractor, large (No.1R045). Labyrinth ring can now be removed. (**Fig. 7**)

Fig. 6

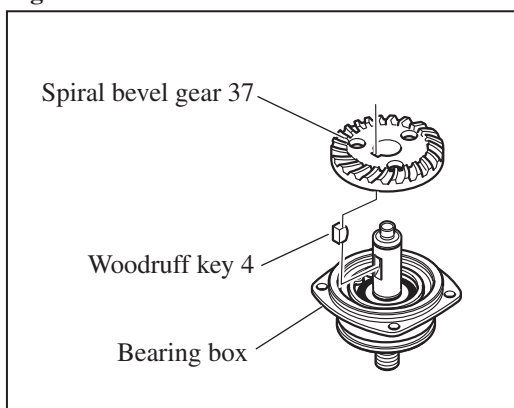
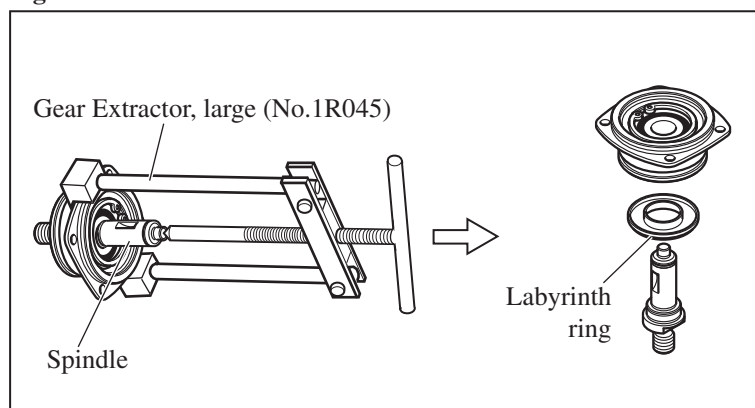

Fig. 7



- 5) Remove Retaining ring R-32 from Bearing box with Retaining Ring S and R Pliers (No.1R291).
- 6) By striking Bearing box against the surface of a work bench, Ball bearing 6201DDW and Flat washer 12 can be removed from Bearing box as illustrated in **Fig. 8**.

If it is difficult to remove the ball bearing, remove using arbor press.

Fig. 8

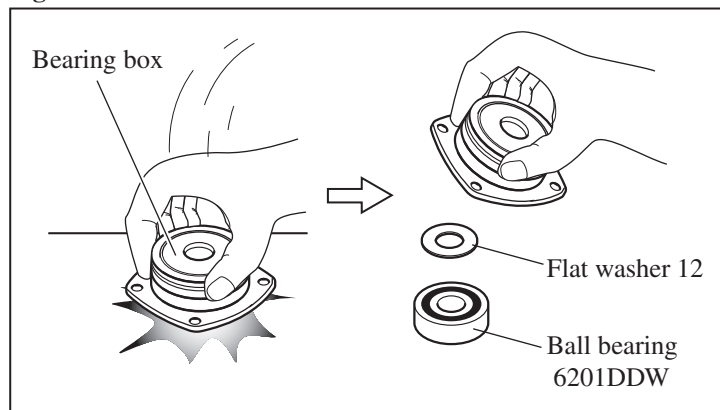

► Repair

[3] -2. Spiral Bevel Gear 37 and Ball Bearing 6201DDW (cont.)

ASSEMBLING

Do the reverse of the disassembling steps.

Important: Do not forget to install Labyrinth ring because it is an important part that prevents dust from entering into Bearing box. (Fig. 9)

How to fit Retaining ring S-12 in place

See Fig. 10.

After installing Spiral bevel gear 37 and Wave washer 12 on Spindle;

- 1) Put Retaining ring S-12 on Retaining Ring Setting Jig (No.1R343) from the tapered end of the jig.
- 2) Put the jig onto Spindle, then put Bearing Setting Pipe 20-12.2 (No.1R028) over the jig.
- 3) Using arbor press, press down the pipe till the retaining ring is securely fitted in place on Spindle with a snap.

Fig. 9

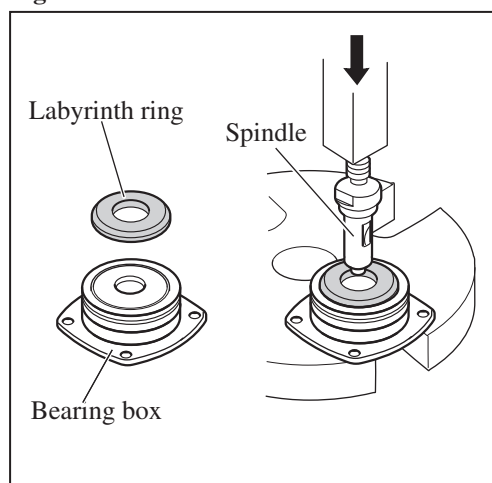
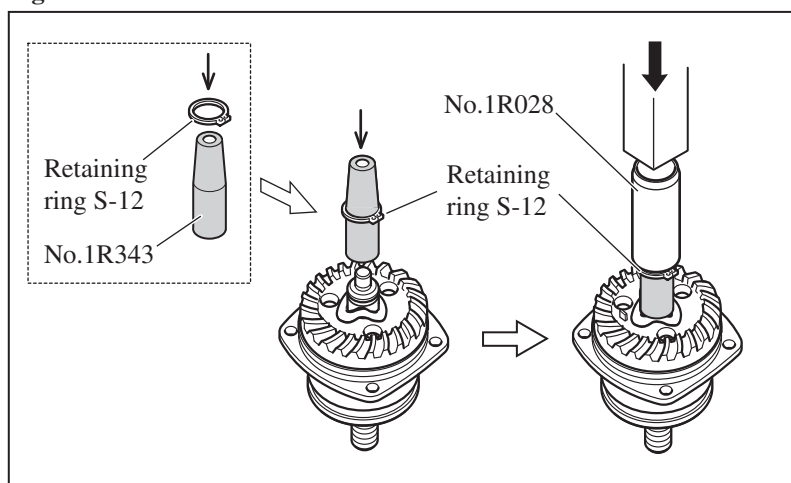

Fig. 10



[3] -3. Disassembling/Assembling Shaft Lock Mechanism

DISASSEMBLING

- 1) Remove Bearing box from Gear housing.
- 2) Pull off Shoulder pin 4 with pliers while pushing Pin cap with finger. (Fig. 11)

Note: Do not pull off Shoulder pin 4 without holding Pin cap because Compression spring 8 would sling Pin cap.

ASSEMBLING

Push Shoulder pin 4 through Gear housing and Compression spring 8 into Pin cap.

Note: Do not reuse removed Pin cap because removal of Shoulder pin 4 damages the inside surface of Pin cap, producing plastic dust. Therefore, be sure to use a new Pin cap for replacement and to remove all the plastic dust on Shoulder pin 4.

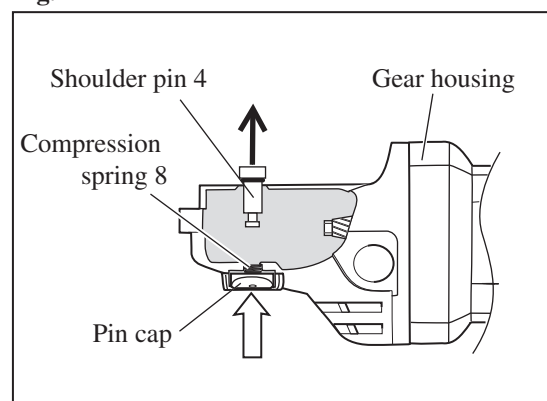

Fig. 11



[3] -4. Tightening Tapping Screws That Fasten the Field

Tighten the two tapping screws that fasten Baffle plate and Field to the recommended torque of 1.1 - 1.3 Nm.

► **Circuit diagram**

| Color index of lead wires' sheath | |
|-----------------------------------|---|
| Black |  |
| Red |  |
| Clear |  |

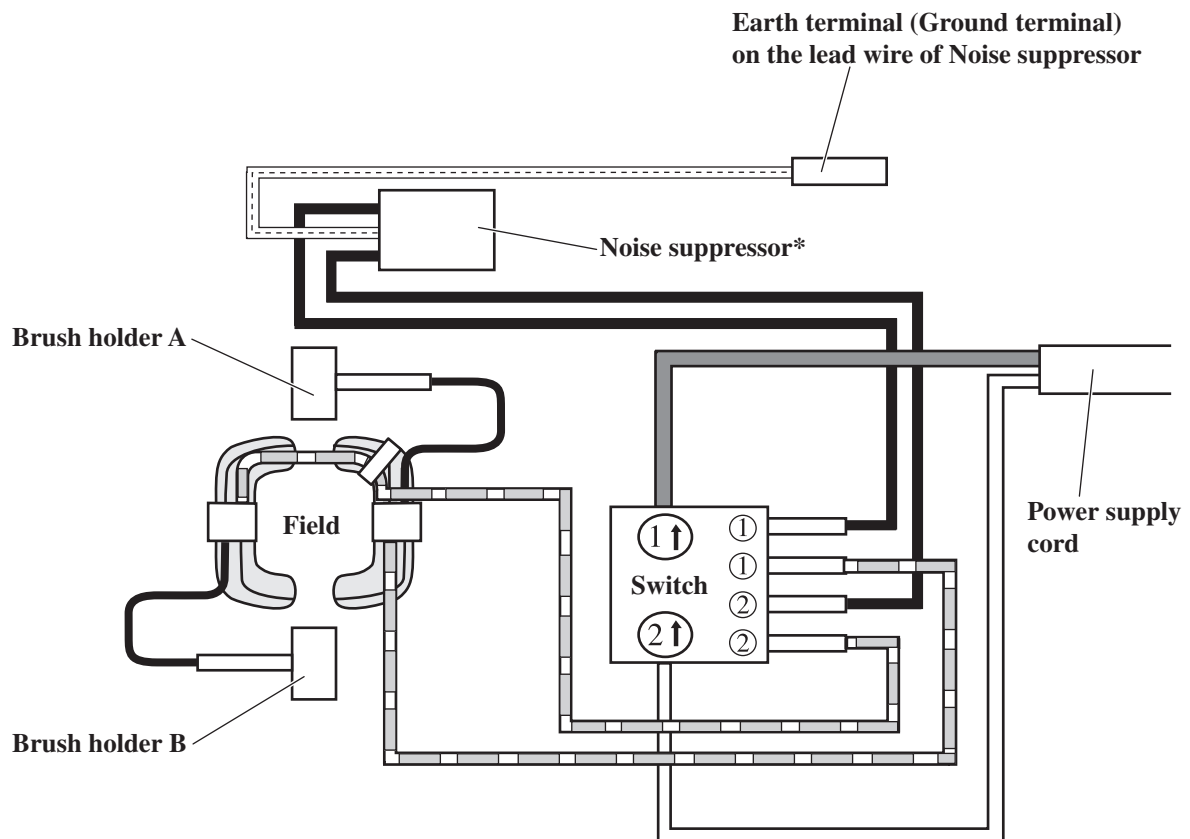

*Some countries do not use noise suppressor

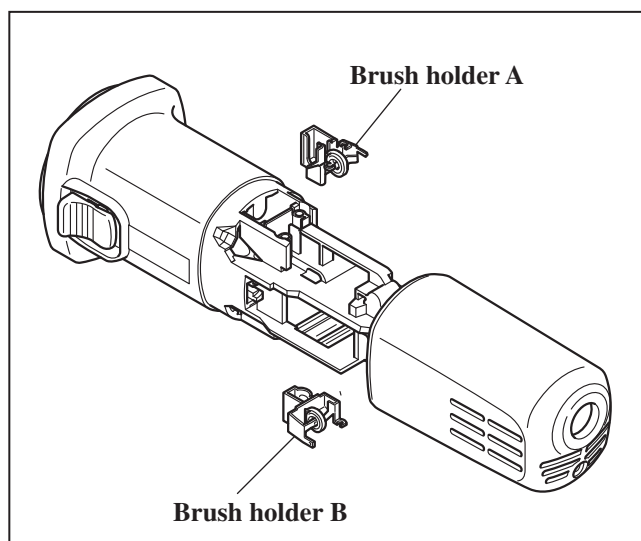

▶ Wiring diagram

[1] Connecting Lead Wires of Power Supply Cord with Switch

Connect the lead wires with Switch as illustrated in Fig. 12.

Fig. 12

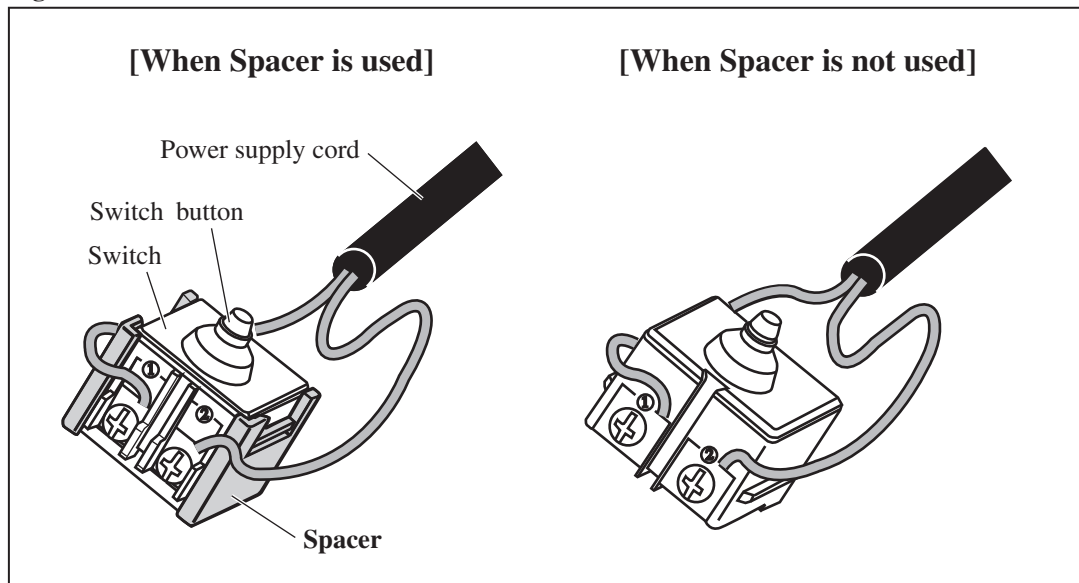

[2] Wiring of Field Lead Wires in the Rear of Motor Housing

[2] -1. Rear End

Route Field lead wires as illustrated in Figs. 13 - 16.

Fig. 13

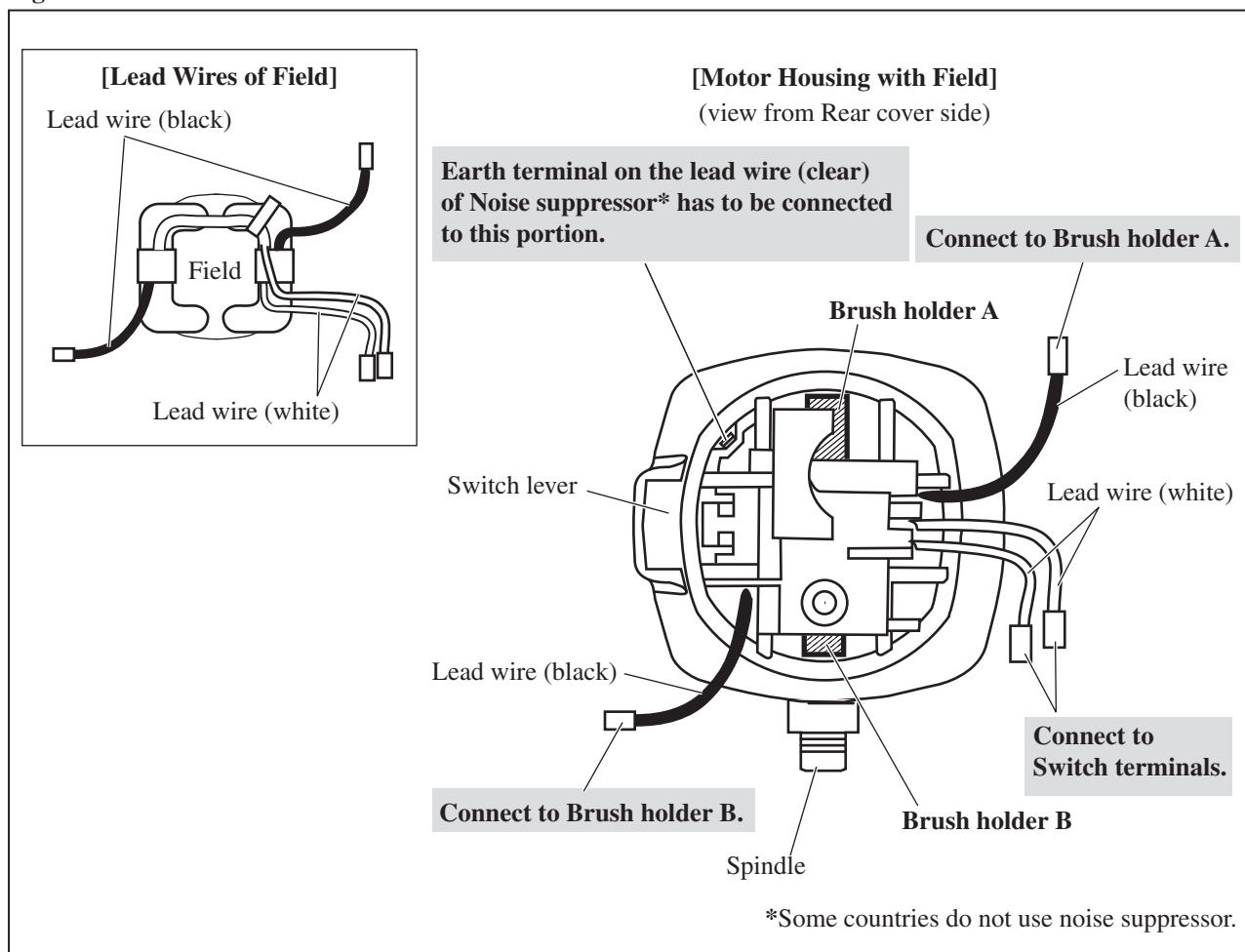

► **Wiring diagram**

[2] **Wiring of Field Lead Wires in the Rear of Motor Housing (cont.)**

[2] -2. **Right Side and Bottom**

Fig. 14

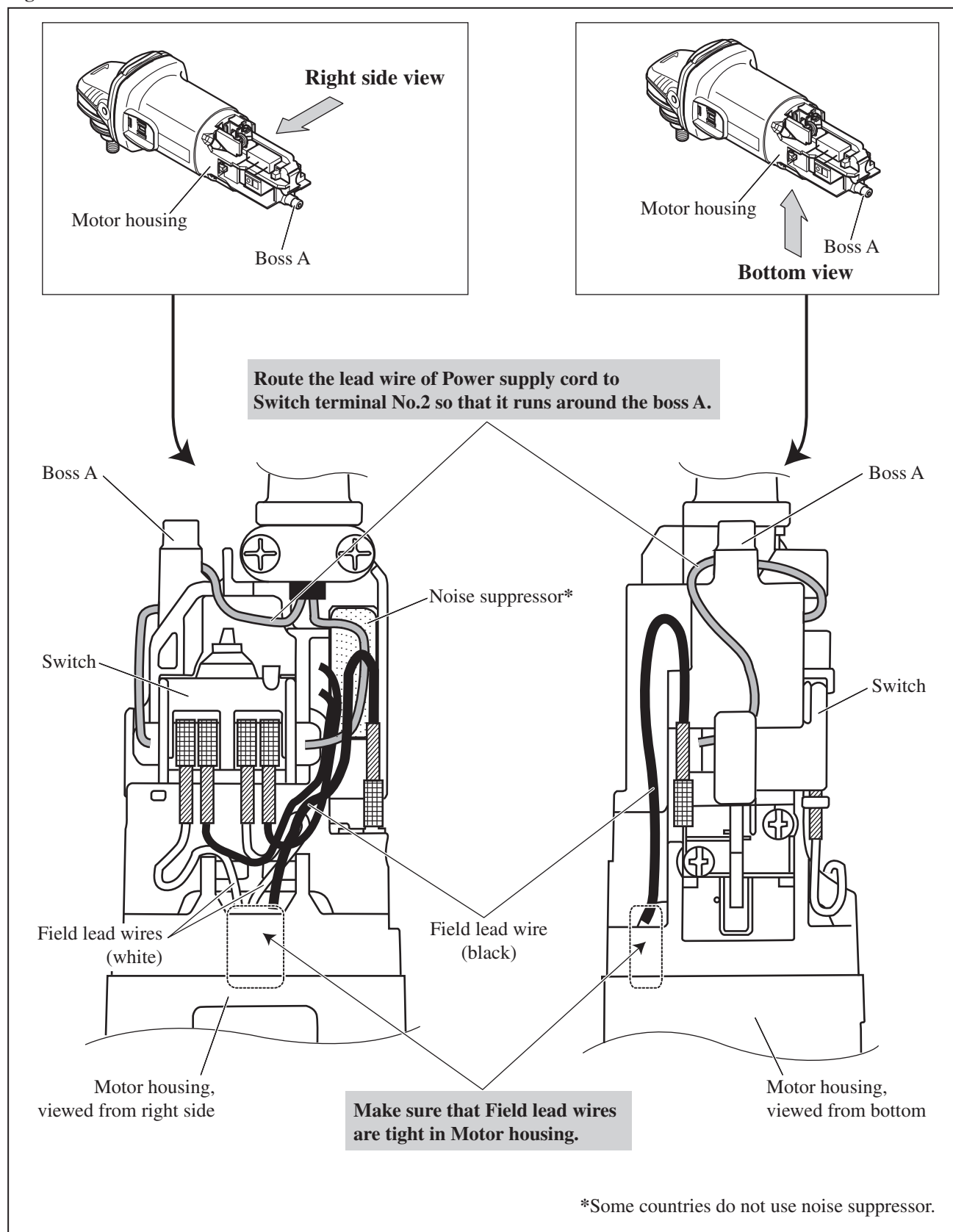

▶ **Wiring diagram**

[2] **Wiring of Field Lead Wires in the Rear of Motor Housing (cont.)**

[2] -3. **Left Side**

Fig. 15

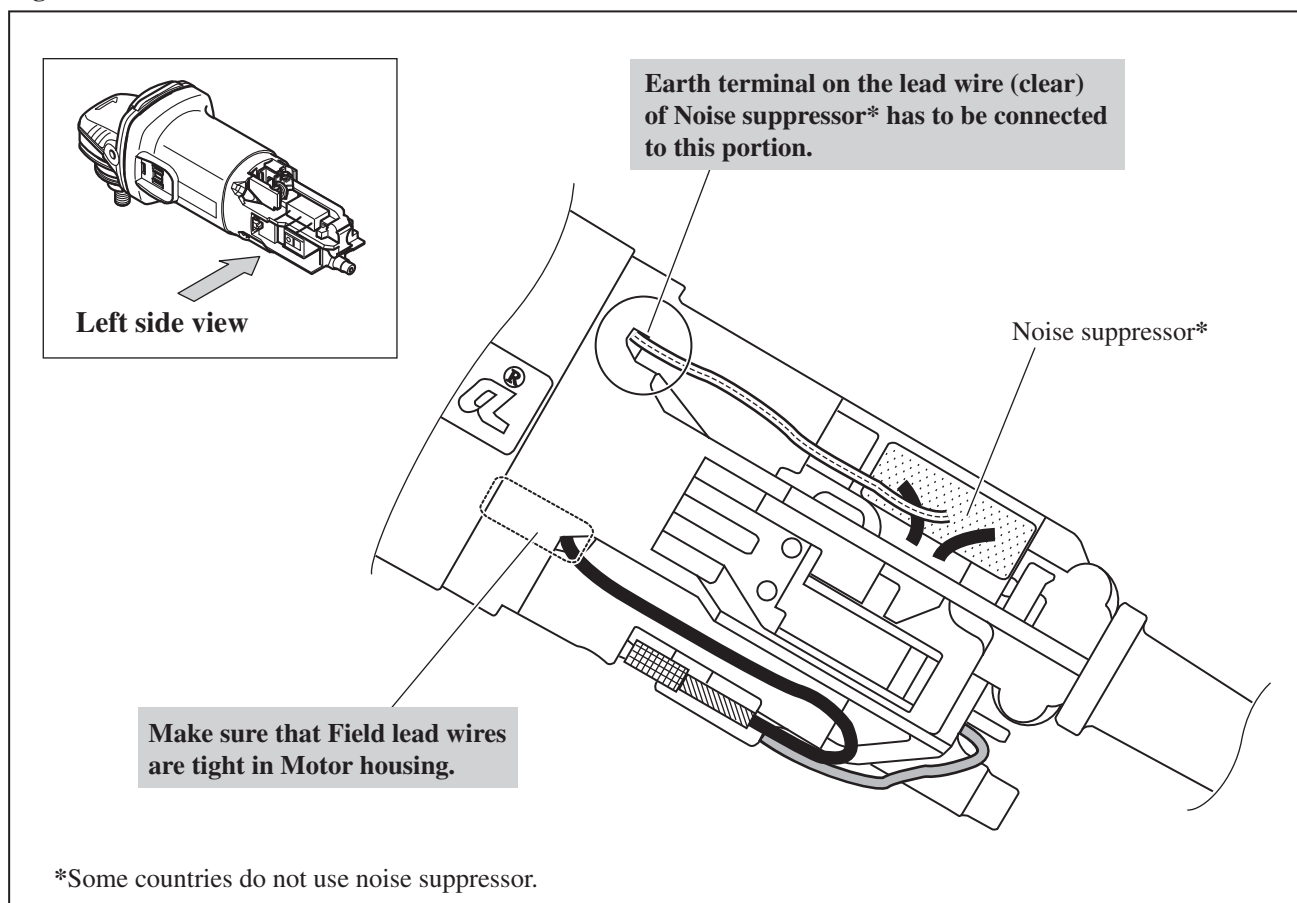

[2] -4. **Top**

Fig. 16

