

TECHNICAL INFORMATION



PRODUCT

P 1 / 6

Models No. ▶ 9563H / 9561CH, 9561CVH, 9564H / 9562CH, 9562CVH, 9565H

Description ▶ Angle grinder 100mm(4") / 115mm(4-1/2") / 125mm(5")

CONCEPTION AND MAIN APPLICATIONS

Models 9563H, 9564H and 9565H perform 1,100W continuous rating input by Field upgrade of the current 9563 series.

Models 9561CH, 9561CVH, 9562CH and 9562CVH perform 1,200W by Field upgrade of the current 9561C series.

Following is the main features inherited from the predecessors.

All models: Super Joint System (SJS).

9561CH, 9562CH: Electronic limiter, Electric controller and Auto break carbon brush.

9561CVH, 9562CVH: Speed control dial in addition to the features of 9561CH and 9562CH

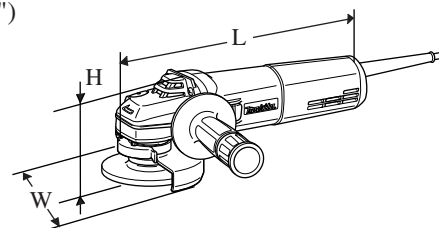

Dimensions : mm (")					
Model No.	9563H	9564H	9565H	9561CH / 9561CVH	9562CH / 9562CVH
Width (W)	120 (4-3/4)	129 (5-1/16)	139 (5-1/2)	129 (5-1/16)	139 (5-1/2)
Height (H)	103 (4)				
Length (L)	299 (11-3/4)			289 (11-3/8)	

Specification

Model No.	Current (A)					Cycle (Hz)	Continuous Rating (W)		Max. Output(W)
	110V	120V	220V	230V	240V		Input	Output	
9563H 9564H 9565H	10.5	10.0	5.3	5.0	4.8	50 / 60	1,100	700	1,300
9561CH/CVH 9562CH/CVH	11.5	11.0	5.7	5.5	5.3	50 / 60	1,200	750 (110V-120V) 800 (220V-240V)	1,800 (110V) 2,000 (120V-240V)

		9563H	9564H	9565H	9561CH	9561CVH	9562CH	9562CVH
Wheel size : mm (")	Diameter	100 (4)	115 (4-1/2)	125 (5)	115 (4-1/2)		125 (5)	
	Hole diameter	16 (5/8)		22.23 (7/8)				
	Thickness	6 (1/4)						
No load speed : (min - max rpm)	North America	10,500			2,800 - 10,500		10,500	2,800 - 10,500
	Other countries	11,000			2,800 - 11,000		11,000	2,800 - 11,000
Super joint system (SJS)		Yes						
Electronic	Current limiter	No			Yes			
	Speed control dial	No			No	Yes	No	Yes
	Soft starter	No			Yes			
	Constant speed	No			Yes			
Cord length : m (ft)		2.5 (8.2)						
Net weight :Kg (lbs)		1.8 (3.9)						

Standard equipment

For 100mm(4") angle grinders	For 115mm (4-1/2") angle grinders	For 125mm (5") angle grinders
Depressed center wheel 100-24 1	Depressed center wheel 115-24 1	Depressed center wheel 125-24 1
Lock nut wrench 20 1	Lock nut wrench 28 1	Lock nut wrench 35 1
Grip 36 complete 1	Grip 36 complete 1	Grip 36 complete 1

Note: The standard equipment for the tool shown above may differ from country to country.

Optional accessories

Depressed center wheel	Wheel cover for wire cup brush set	Abrasive cut off wheel
Rubber pad	Wire bevel brush set	Wheel cover
Dust collection wheel guard	Wheel cover for wire bevel brush set	Inner flange
Abrasive disc	Diamond wheel	Lock nut
Wire cup brush set	Base assembly	Lock nut for cut off wheel

Note: The applicable optional accessories differ by specifications.

► Repair

CAUTION: Be sure to disconnect the machine from the power source and remove Wheel and Wheel cover before maintenance or repair.

See the instruction manual on how to handle the tool.

[1] NECESSARY REPAIRING TOOLS

Code No.	Descriptions	Purpose
1R217	Ring 22	Extracting Spiral bevel gear 38
1R269	Bearing Extractor (small)	Removing Ball bearing 627DDW
1R291	Retaining Ring S and R Pliers	Removing/ Installing Retaining rings S-12
1R340	Bearing Retainer Wrench	Removing/ Installing Bearing retainer 19-33

[2] LUBRICATION

- 1) Supply 15g of Makita grease SG No.0 into the Gear room.
- 2) Apply a little amount of molybdenum disulfide lubricating oil to inside of Spiral bevel gear 11 and Lock spring 12.

[3] DISASSEMBLY/ASSEMBLY

[3] -1. Replacing Armature and Spiral Bevel Gear 11

DISASSEMBLY

- 1) Remove Rear cover by unscrewing one 4x8 Tapping screw.
- 2) Remove the tail of Spiral spring from Carbon brush and hook it on the edge of Brush holder.
Leave the half of Carbon brush in Brush holder by pulling it off from Commutator as illustrated in **Fig.1**.

Fig.1

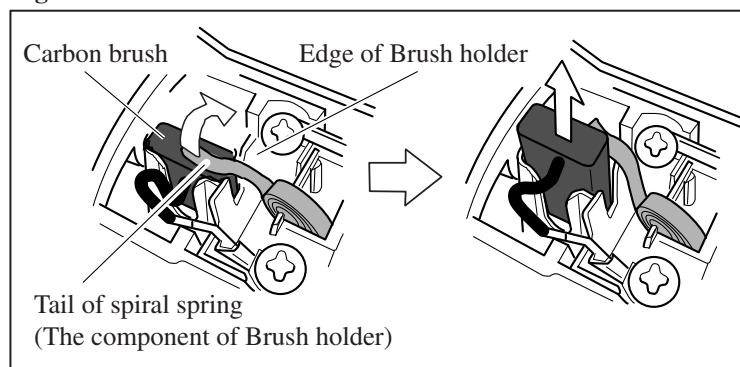

- 3) Remove Gear housing by unscrewing four 4x8 Tapping screws.
- 4) Remove Armature together with Gear housing cover.
- 5) While catching Armature firmly, remove Flat washer 6 by turning Right-handed Hex. nut M6 counterclockwise with Wrench 10.
- 6) Remove Spiral bevel gear 11 and Lock spring 12 with 1R269. Refer to **Fig.2**.
- 7) Remove Retaining ring S-12 with 1R291.
- 8) While fixing Gear housing cover using U-shaped plate of arbor press, remove Armature using arbor press.

Fig.2

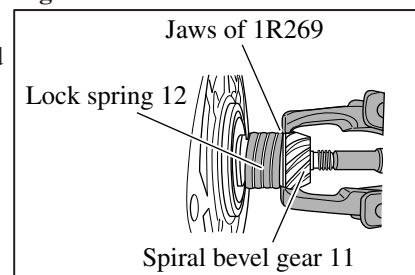

Do the following three steps only for 9561CH, 9561CVH, 9562CH, 9562CVH

- 9) Pick up three tabs of Self lock 6 one by one with fine tweezers as illustrated in **Fig.3**, and the Self lock 6 can be removed.
- 10) Remove Magnet sleeve and Wave washer 6.
- 11) Remove Ball bearing 627DDW with 1R269.

Fig.3

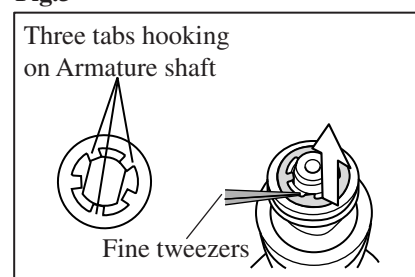

► Repair

[3] -1. Replacing Armature and Spiral Bevel Gear 11 (cont.)

ASSEMBLY

Do the following four steps only for 9561CH, 9561CVH, 9562CH, 9562CVH

- 1) Install Wave washer 6 into Armature shaft as illustrated in **Fig.4**. Pay attention to the direction of the Wave washer 6.
- 2) Return the nails of Lock spring 12 to be flat if their shapes are deformed.
- 3) Install Magnet sleeve into Armature shaft.
- 4) Press down Self lock 6 into Armature shaft by fingers as illustrated in **Fig.5** until Wave washer 6 is crushed to be flat. Pay attention to the direction of the Self lock 6.

Note: Be sure to replace Lock spring 12 when replacing Spiral bevel gear 11.

Fig.4

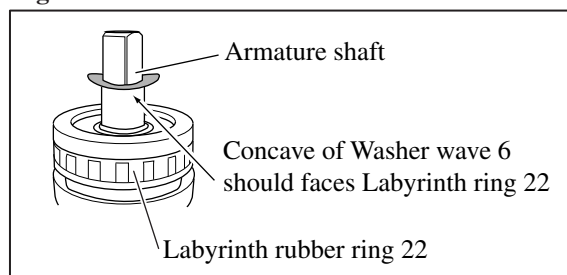
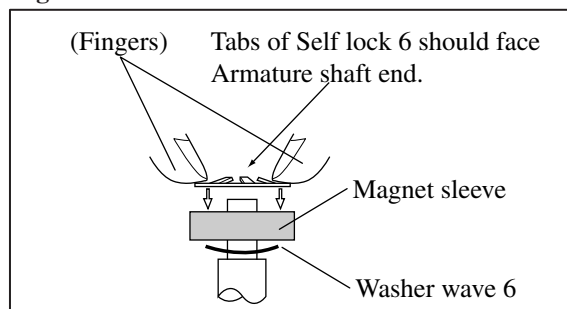

Fig.5



[3] -2. Replacing Spiral Bevel Gear 38 and Ball Bearing 6201DDW

They can be replaced without disassembling the motor.

DISASSEMBLY

- 1) Remove Bearing box by unscrewing four M4x16 Hex head bolts. **Note: When Bearing box can not be removed by step 1), strike the contact area of Gear housing cover and Gear housing complete on the Bearing box side with Plastic hammer. See Fig.6.**
- 2) After placing Bearing box on 1R217, push out Spindle using arbor press as illustrated in **Fig.7**.
- 3) Clamp Bearing box using Vise. Remove Bearing retainer 19-33 by turning it counterclockwise with 1R340. Refer to **Fig.8**.
- 4) Remove Ball bearing 6201DDW by striking Bearing box against the workbench. If the Ball bearing 6201DDW fits in bearing box too tightly, remove it using arbor press.

Fig.6

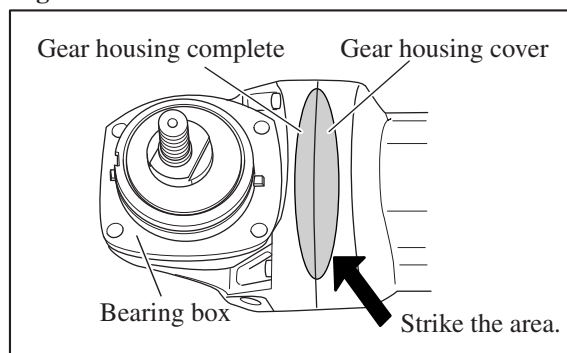

Fig.7

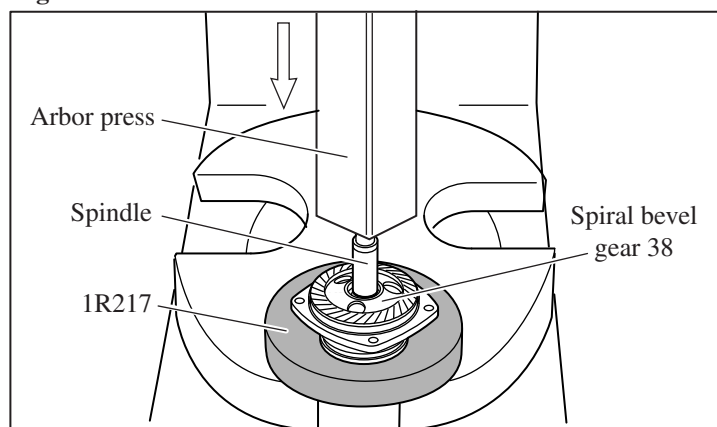
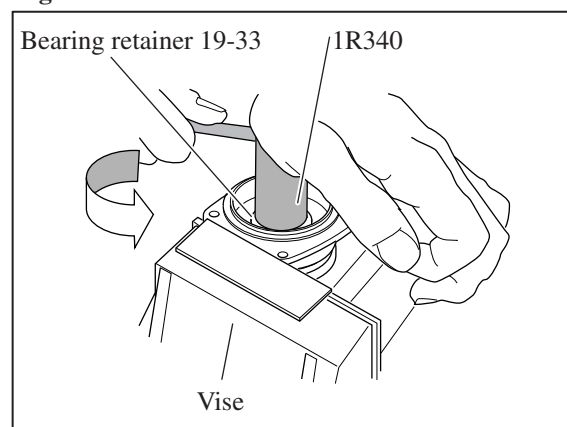

Fig.8



ASSEMBLY

Do the reverse of the disassembling steps.

Four pieces of Makita genuine Hex. socket head bolts M4x16 (Part No. 265490-6 per one piece) are threadlocker-coated for fixing Bearing box to Gear housing complete firmly.

When reuse them, be sure to apply adhesive (for example: Threebond 1321B/ 1342 or LocTite 242) to the threads.

► Repair

[4] Disassembling Shaft Lock Section

When removing Pin 7 from Pin cap, the inside of the Pin cap is shaved.

Replace the Pin cap by the new one.

After removing the shaves of the Pin cap from the Pin 7, insert the new Pin cap in place.

[5] Connecting Receptacle of Carbon Brush to Terminal of Brush Holder

Connect the receptacle of carbon brush with the terminal of brush holder

by pushing the receptacle in arrow direction illustrated in **Fig.9**.

Fig. 9

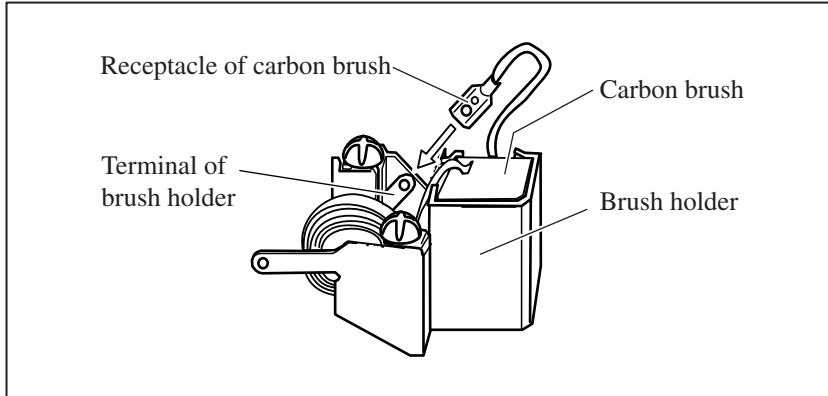

Push the receptacle of carbon brush until it stops as illustrated in **Fig.10**.

Fig.10

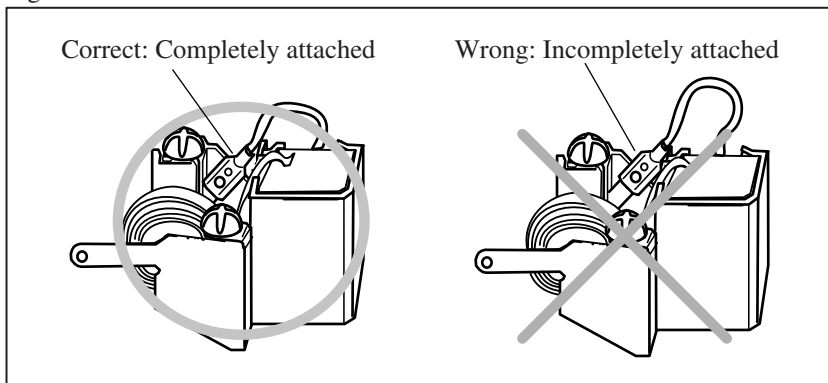

▶ **Circuit diagram**

Model 9563H, 9564H, 9565H
(without Controller)

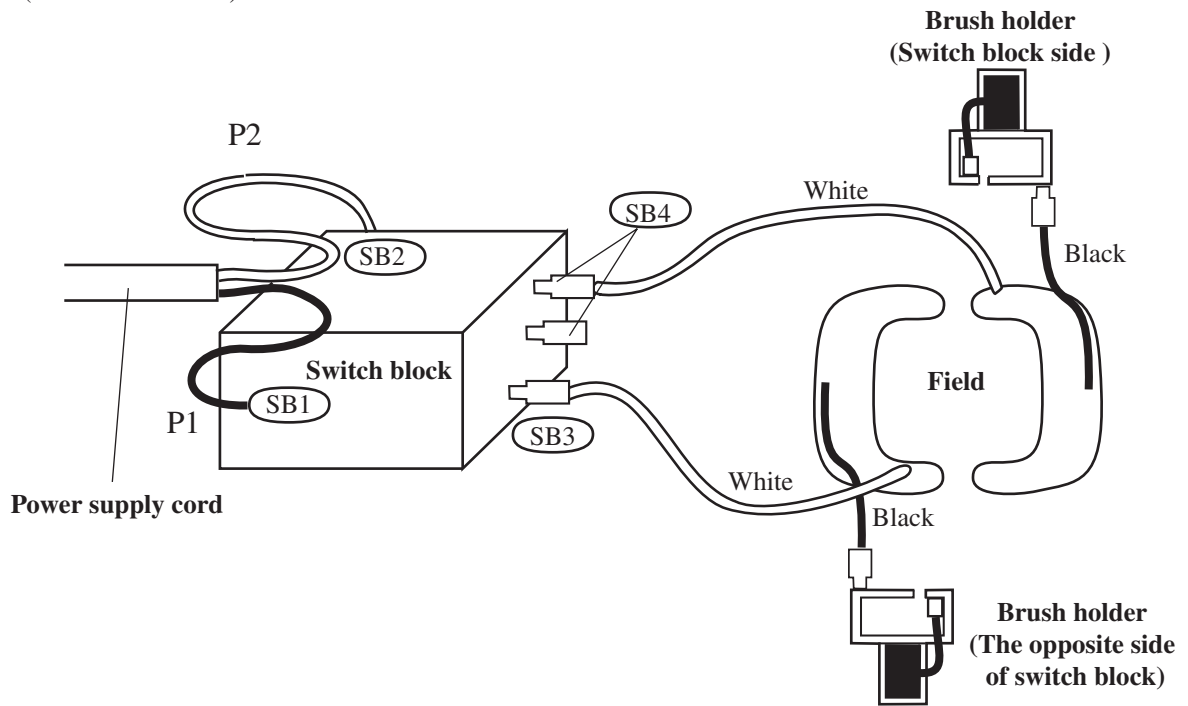

< Note > The numbers, SB1, SB2, SB3 and SB4 are indicated on the switch block.

Model 9561CH, 9561CVH, 9562CH, 9562CVH
(with Controller)

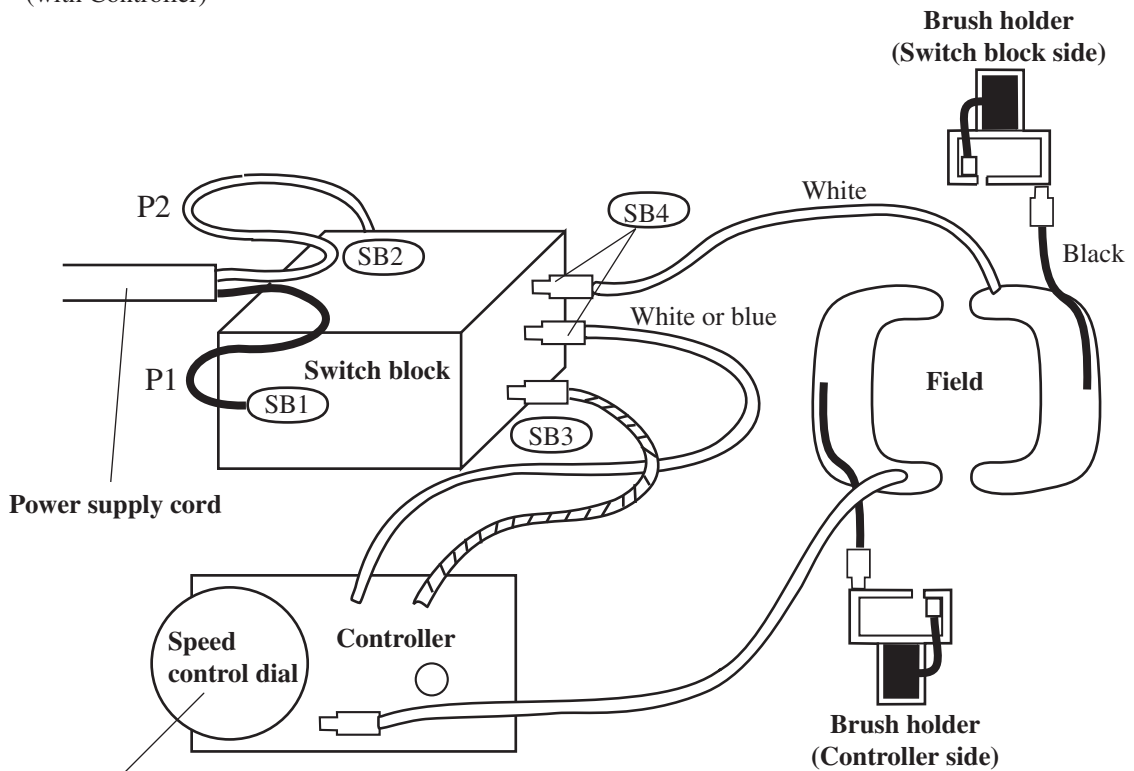

Models 9561CH and 9562CH do not have speed control dial.

< Note > The numbers, SB1, SB2, SB3 and SB4 are indicated on the switch block.

► **Wiring diagram**

Model 9563H, 9564H, 9565H

(without controller)

Except for the part near the receptacle, there should be no slack of Field lead wire in motor housing.
Therefore, pull the Field lead wire to provide a slack here. It prevents the receptacle from having the accidental stress.

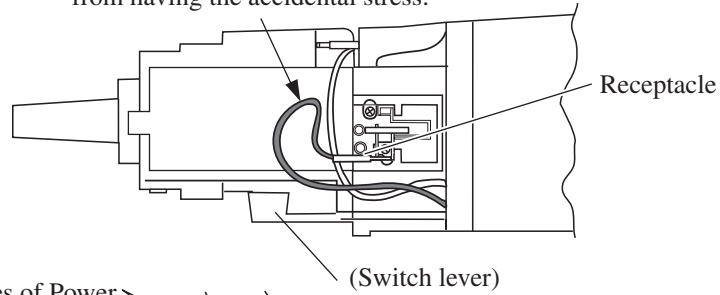

Route lead wires of Power supply cord to nearby Strain relief as shown by arrows.

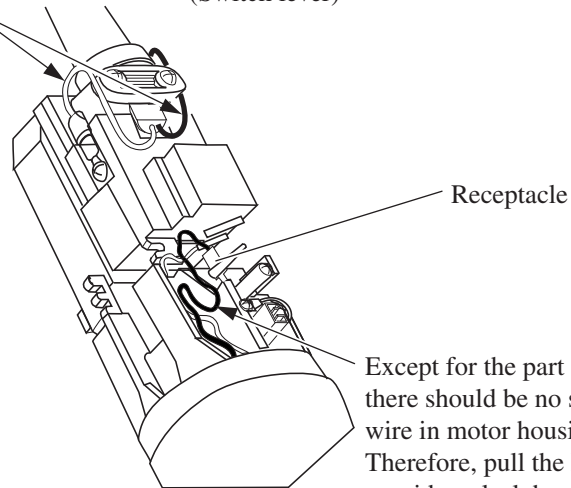

Except for the part near the receptacle, there should be no slack of Field lead wire in motor housing.
Therefore, pull the Field lead wire to provide a slack here. It prevents the receptacle from having the accidental stress.

Model 9561CH, 9561CVH, 9562CH, 9562CVH

(with controller)

Put the lead wires into the lead wire holder.

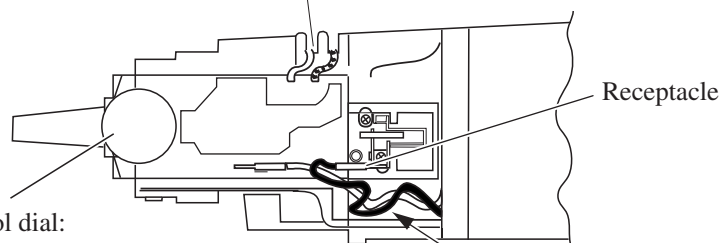

Speed control dial:
9561CH and 9562CH only

Except for the part near the receptacle, there should be no slack of Field lead wire in motor housing.
Therefore, pull the Field lead wire to provide a slack here. It prevents the receptacle from having the accidental stress.

Route lead wires of Power supply cord to nearby Strain relief as shown by arrows.

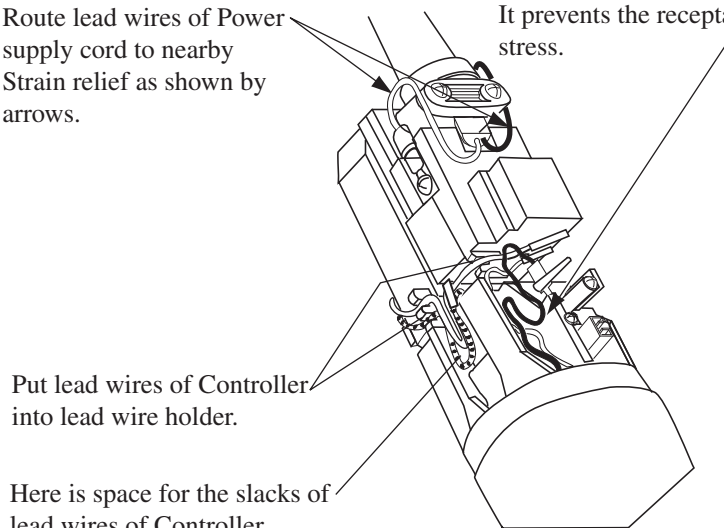

Put lead wires of Controller into lead wire holder.

Here is space for the slacks of lead wires of Controller.