

TECHNICAL INFORMATION



PRODUCT

P 1 / 8

Models No. ▶ 9562, 9565, 9562C, 9562CV, 9565C, 9565CV

Description ▶ Angle grinder 125mm (5")

CONCEPTION AND MAIN APPLICATIONS

New series of 125mm (5") angle grinders are equipped with "Super Joint System-SJS" for protection of user and machine from the shock by accidental spindle lock.

9562C and 9565C are equipped with electronic feature for constant speed, current limiting and soft start, beside "Super Joint System-SJS".

9562CV and 9565CV are equipped with electronic speed control, in addition to the features of 9562C and 9565C.

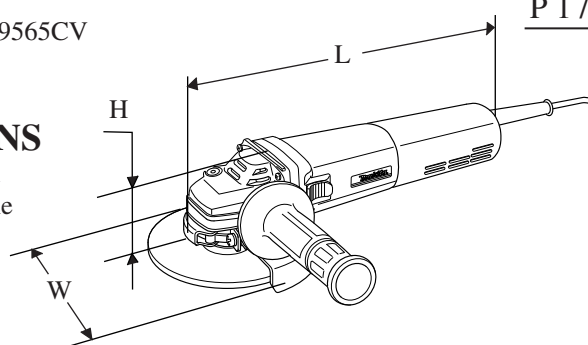

Dimensions : mm (")		
Model No.	9562, C, CV	9565, C, CV
Width (W)	139 (5-1/2)	139 (5-1/2)
Height (H)	103 (4)	103 (4)
Length (L)	289 (11-3/8)	299 (11-3/4)

► Specification

Model No.	Current (A)					Cycle (Hz)	Continuous Rating (W)		Max. Output(W)
	110V	120V	220V	230V	240V		Input	Output	
9562	—	7.0	3.8	3.7	3.5	50 / 60	800	480	1,000
9565	8.6	7.9	4.3	4.1	3.9	50 / 60	900	540	1,300
9562C/CV	—	9.6	5.3	5.0	4.8	50 / 60	1,100	660	1,600 (120V) 1,800 (220 - 240V)
9565C/CV	—	12.0	6.7	6.4	6.1	50 / 60	1,400	840	2,000 (120V) 2,400 (220 - 240V)

Specifications		Model No.	9562	9562C	9562CV	9565	9565C	9565CV
Wheel size : mm (")	Diameter	125 (5)						
	Hole diameter	22.23 (7/8)						
	Thickness	6 (1/4)						
No load speed : (min -max rpm)	North America	10,500	2,800 -10,500	10,500	2,800 -10,500	11,000	2,800 -11,000	11,000
	Other countries	11,000	2,800 -11,000	11,000	2,800 -11,000	11,000	2,800 -11,000	11,000
"Super joint system-S J S"		Yes						
Electronic	Current limiter	No	Yes	Yes	No	Yes	Yes	Yes
	Speed control dial	No	No	Yes	No	No	No	Yes
	Soft starter	No	Yes	Yes	No	Yes	Yes	Yes
	Constant speed	No	Yes	Yes	No	Yes	Yes	Yes
Cord length : m (ft)		2.5 (8.2)						
Net weight :Kg (lbs)		1.7 (3.7)			1.8 (4.0)			

► Standard equipment

- * Grip 36 complete 1 pc.
- * Lock nut wrench 20 1 pc.
- * Depressed center wheel 125-36..... 1 pc.

< Note > The standard equipment for the tool shown may differ from country to country.

► Optional accessories

- * Depressed center wheel 125-24, 36
- * Rubber pad 115
- * Lock nut 14-48
- * Dust collection wheel guard
- * Abrasive disc 125-24,30,50,120
- * Wire cup brush set 90 mm
- * Wheel cover for wire cup brush 90 mm set
- * Inner flange 47 assembly
- * Diamond wheel 125

<1> Replacing spiral bevel gear 11

- (1) Remove tapping screw 4x18 and detach rear cover from motor housing.
And remove carbon brush as illustrated in Fig. 1.
- (2) Remove tapping screw 4x28 and detach gear housing from motor housing.
And remove armature with gear housing cover as illustrated in Fig. 1.

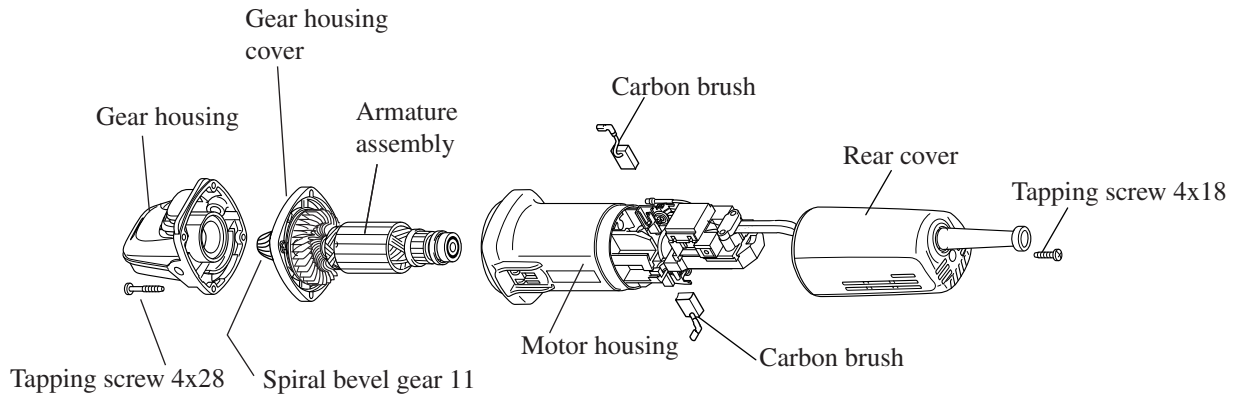

Fig. 1

- (3) Detach hex nut M6 and flat washer 6 from armature as illustrated in Fig.2.

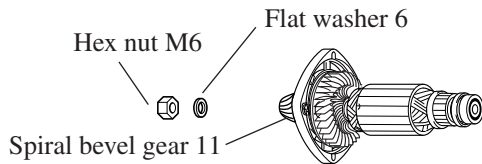

Fig. 2

- (4) Remove spiral bevel gear 11 with bearing extractor No.1R269. And remove lock spring 12 by turning it anti-clockwise. When removing, grip lock spring 12 with gloved hand for anti-skid.

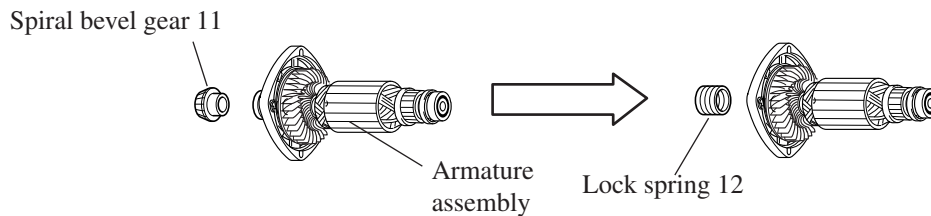

Fig. 3

< Note > Replace lock spring 12 together, when replacing spiral bevel gear 11.

- (5) When assembling spiral bevel gear 11 to armature, take the reverse step.

Attaching carbon brush

Connect the receptacle of carbon brush with the terminal of brush holder by pushing in the direction of the arrow, as illustrated in Fig. 4.

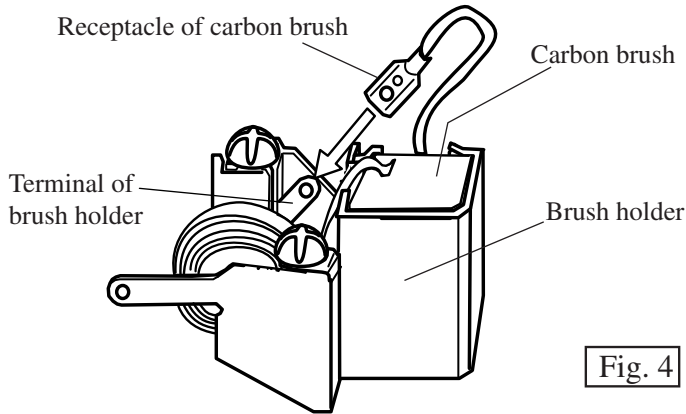

Push the receptacle of carbon brush until it stops as illustrated in Fig. 4A.

Completely attached receptacle of carbon brush

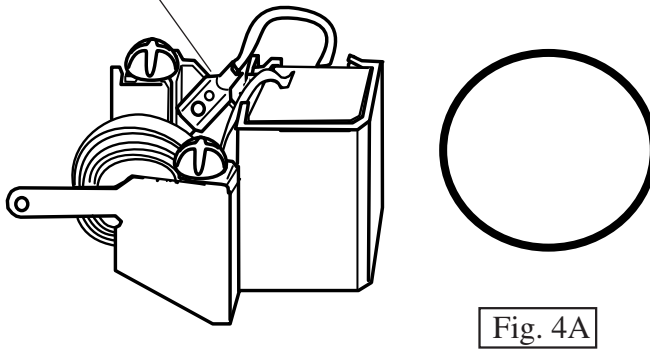

Incompletely attached receptacle of carbon brush

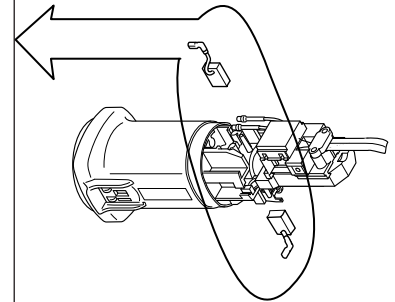
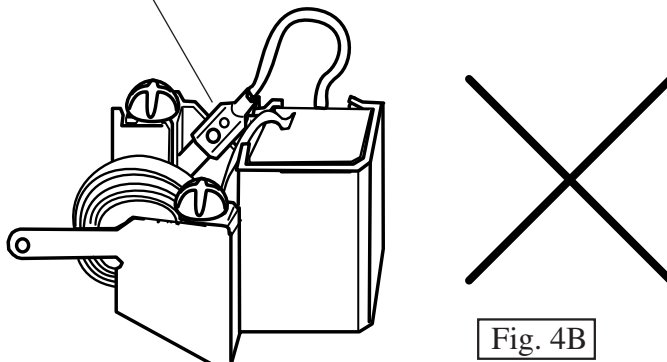

Model 9562C,CV / Model 9565C,CV

with electronic features

Model 9562C and 9565C : without speed control dial

Model 9562CV and 9565CV : with speed control dial

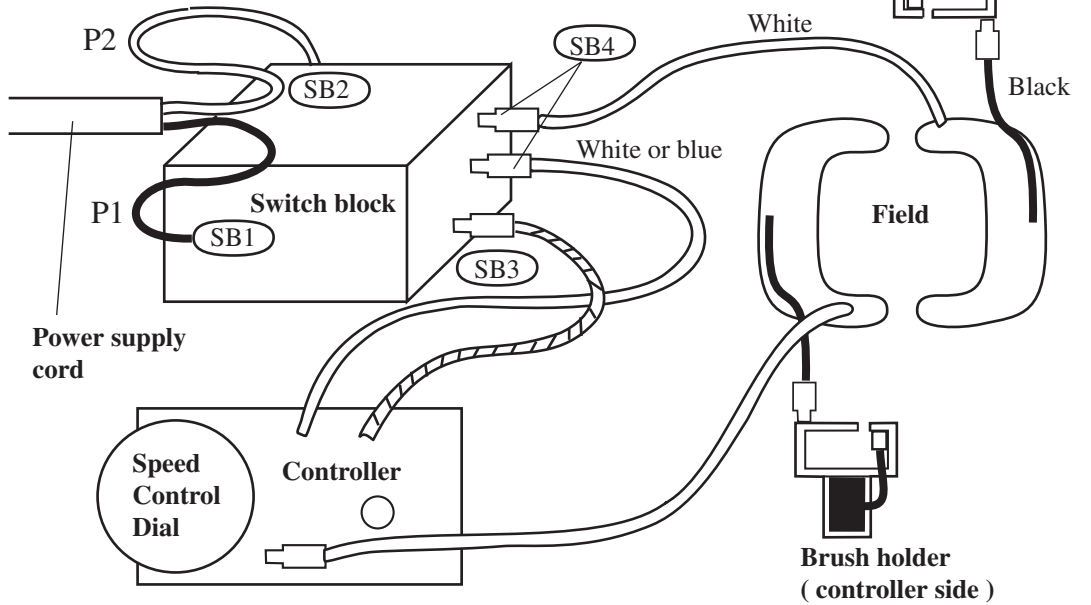

< Note >

The numbers, SB1, SB2, SB3 and SB4 are indicated on the switch block.

Fig. 5

Model 9562 / Model 9565

without electronic features

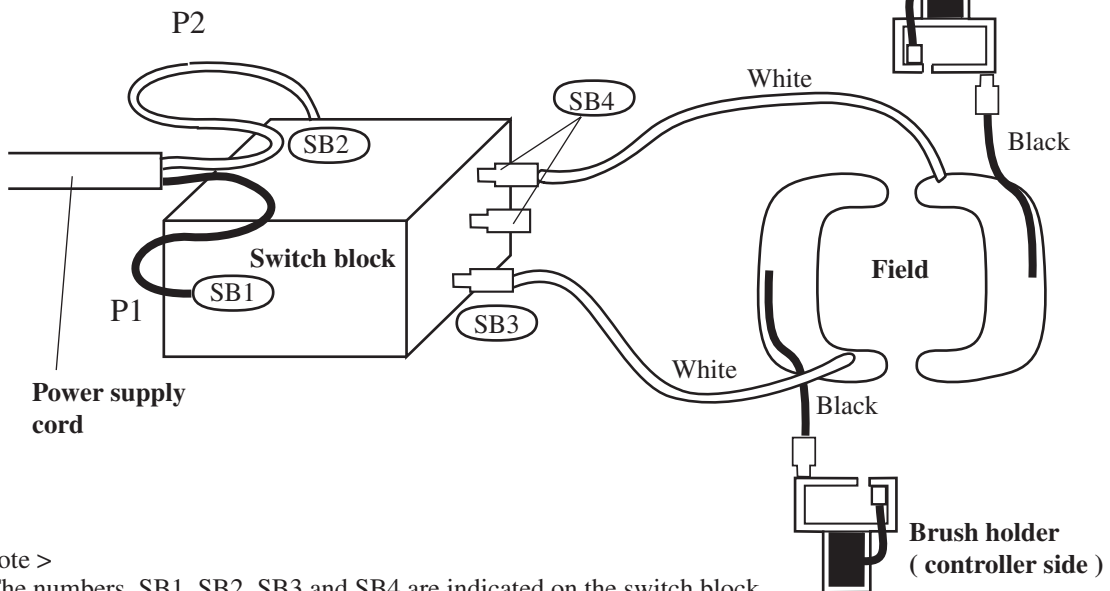

< Note >

The numbers, SB1, SB2, SB3 and SB4 are indicated on the switch block.

Fig. 6

▶ Circuit diagram

Model 9562 / Model 9565
without electronic features
with EMC unit

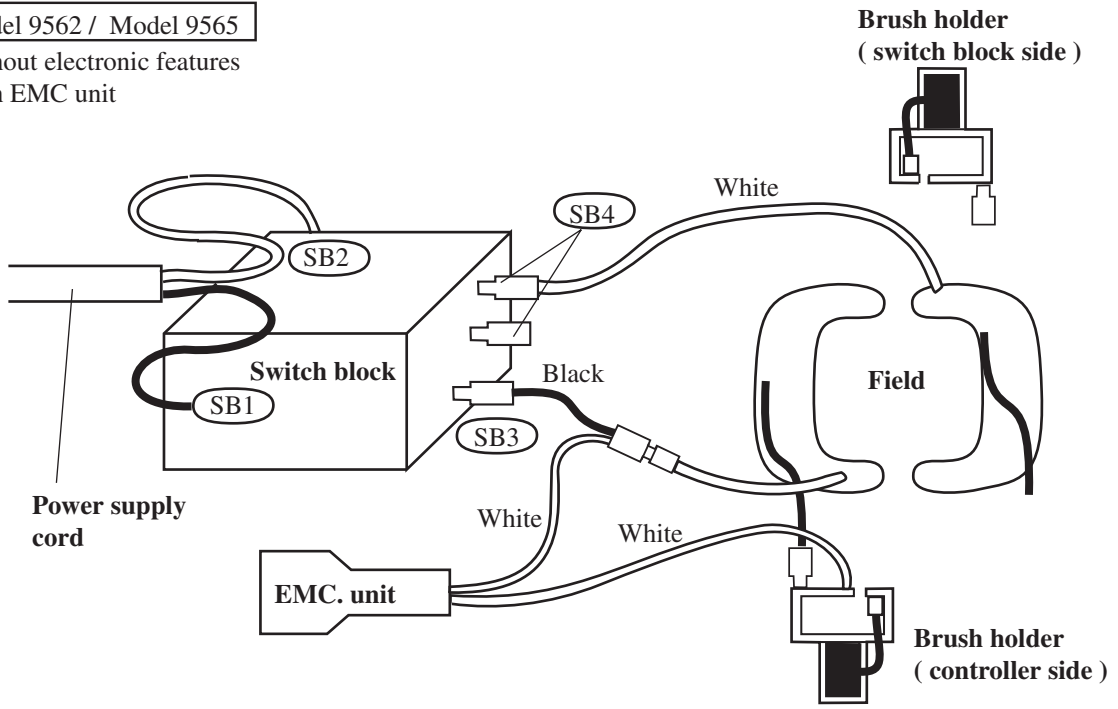

Model 9562C,CV / Model 9565C,CV

with electronic features

Model 9562C and 9565C : without speed control dial

Model 9562CV and 9565CV : with speed control dial

Put the lead wires of controller in the lead holder so that they are not slacken.

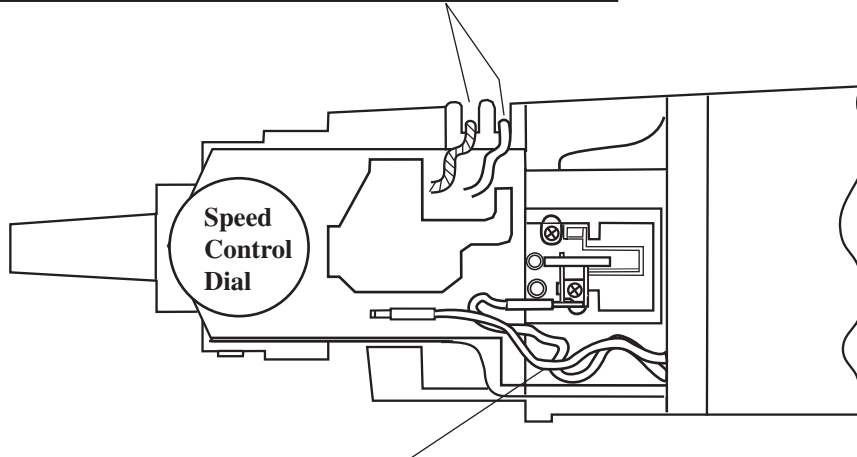

Be careful not to loosen the lead wires of field in motor housing. Put the loosened lead wires in the above place.

Fig. 7

Model 9562C,CV / Model 9565C,CV

with electronic features

Put lead wires of power supply cord by strain relief as illustrated in Fig. 8.

Do not loosen the lead wires of filed in motor housing. Put the loosened ones in the place as illustrated in Fig.8.

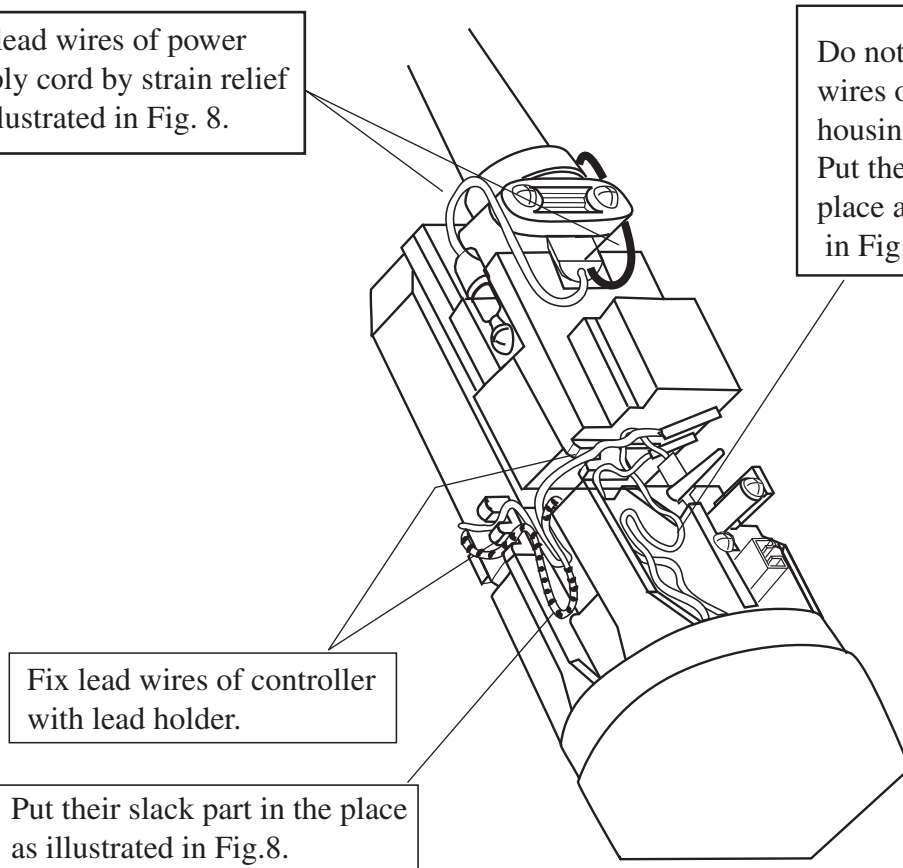

Fix lead wires of controller with lead holder.

Put their slack part in the place as illustrated in Fig.8.

Fig. 8

Model 9562 / Model 9565
without electronic features

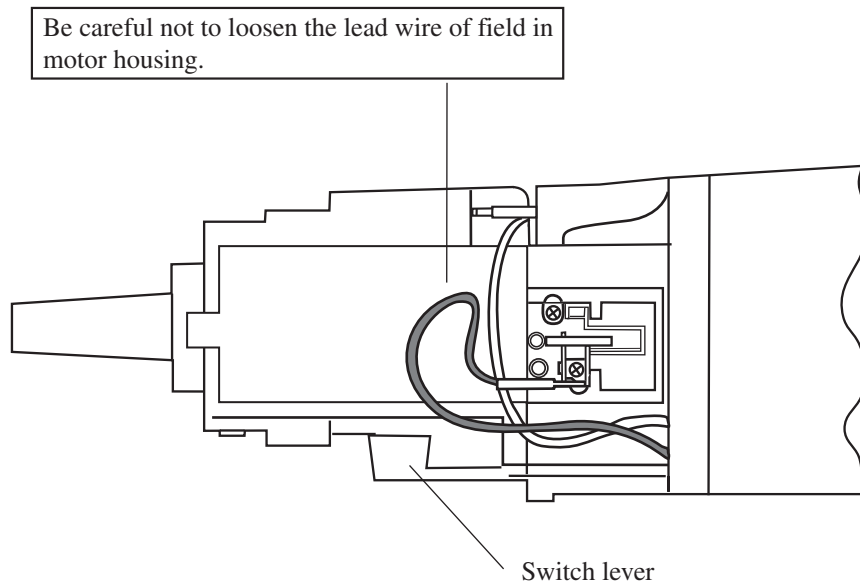

Fig. 9

Model 9562 / Model 9565
without electronic features

Put lead wires of power supply cord by strain relief as illustrated in Fig. 10.

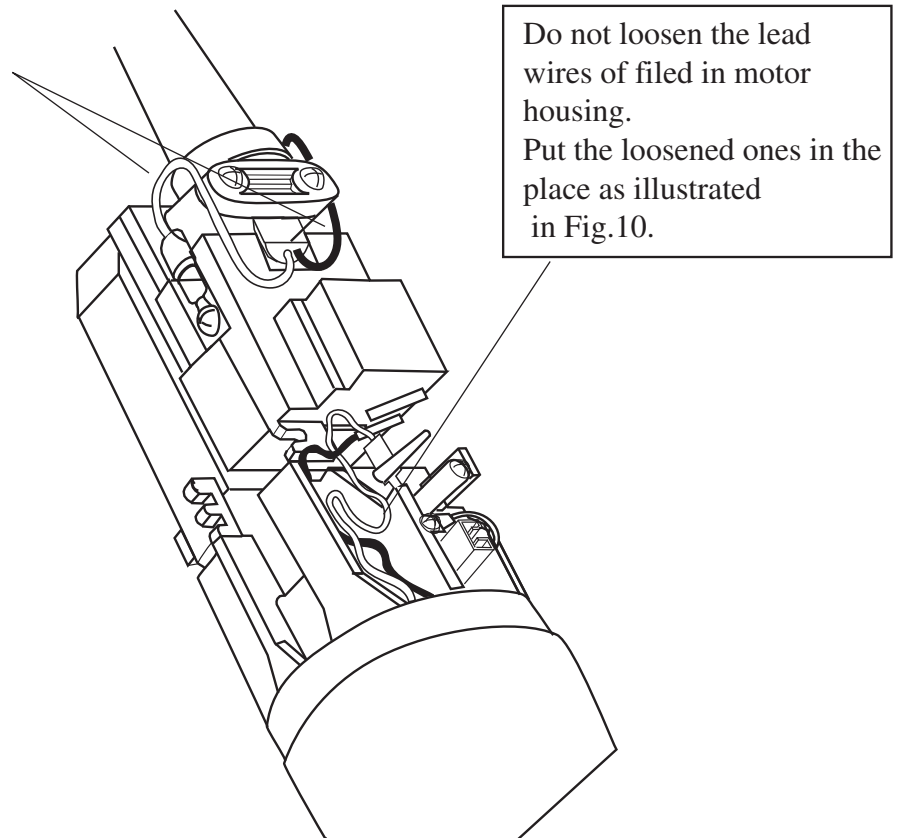

Fig. 10

Model 9562 / Model 9565
without electronic features
with EMC unit

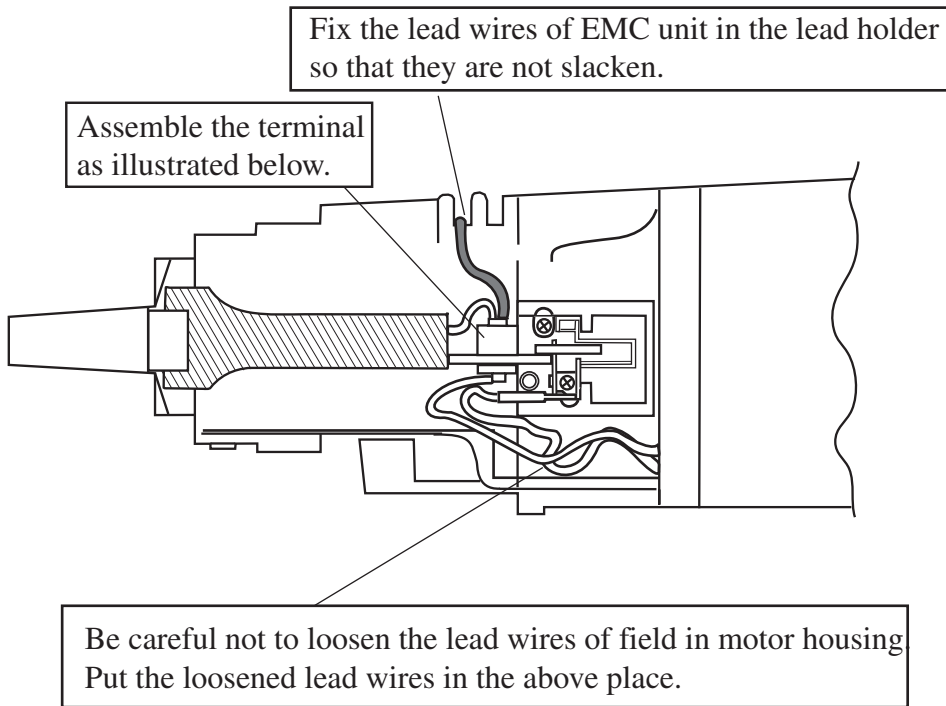

Fig. 11

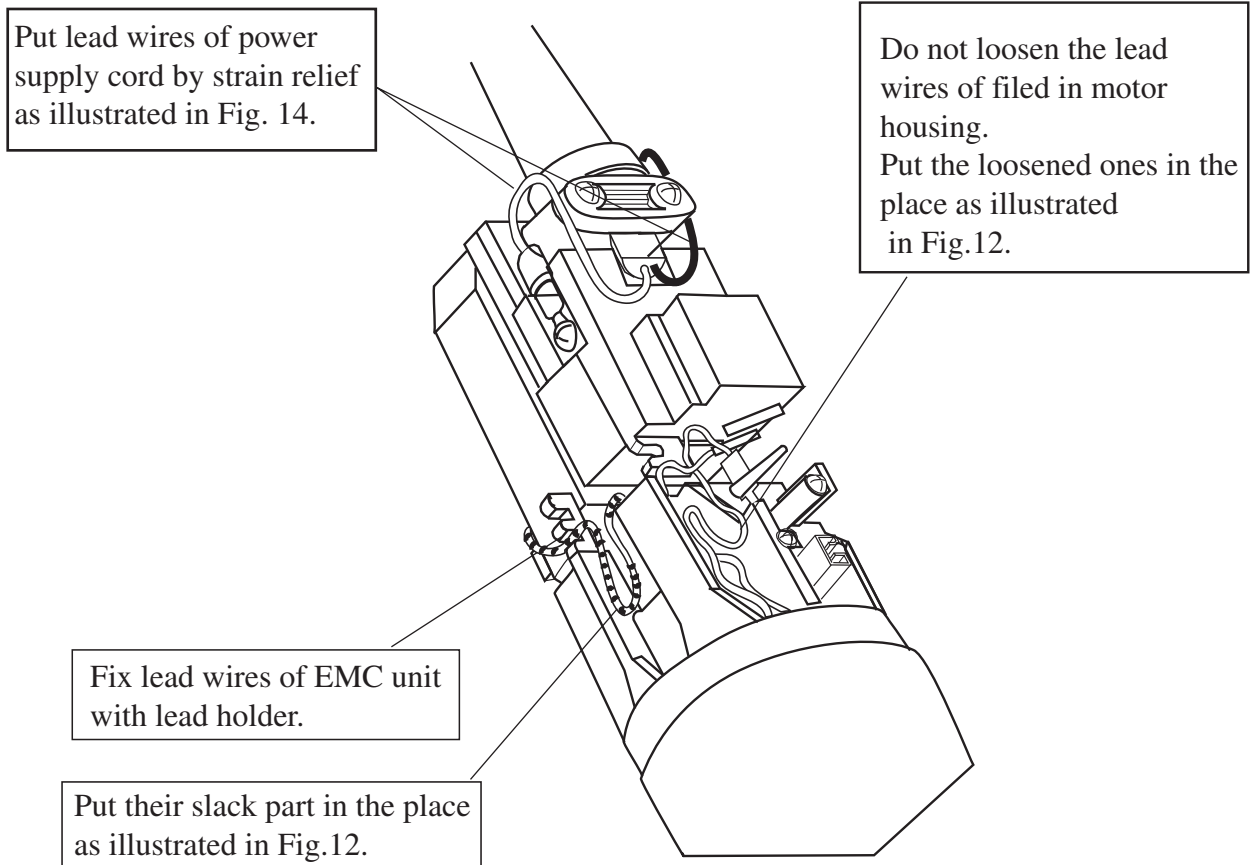

Fig. 12