

# T ECHNICAL INFORMATION



PRODUCT

P 1 / 8

**Model No.** ▶ 9566C / 9566CV

**Description** ▶ 150mm (6" ) Angle grinders

## CONCEPT AND MAIN APPLICATIONS

Model 9566C and 9566CV are 150mm (6" ) version of 1,400W class models 9565C and 9565CV.

The features of 9566C

- \* Equipped with electronic for soft start, current limiter and speed control
- \* "Super Joint System-SJS".

The features of 9566CV

- \* Pre-setting dial for speed control is added to the 9566C's features.

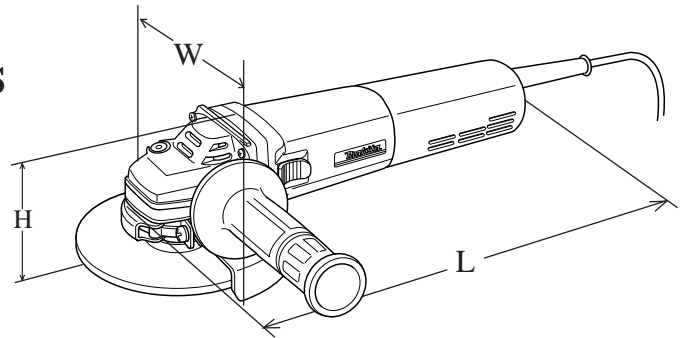

Dimensions : mm ( " )	
Length ( L )	299 ( 11-3/4 )
Width ( W )	169 ( 6-5/8 )
Height ( H )	103 ( 4-1/16 )

## ► Specification

Voltage (V)	Current (A)	Cycle (Hz)	Continuous Rating (W)		Max. Output(W)
			Input	Output	
120	12.0	50 / 60	1,400	840	1,800
220	6.7	50 / 60	1,400	840	2,100
230	6.4	50 / 60	1,400	840	2,100
240	6.1	50 / 60	1,400	840	2,100

Model No.		9566C	9566CV
Wheel size : mm ( " )	Diameter	150 ( 6 )	
	Hole diameter	22.23 ( 7/8 )	
	Thickness	6 ( 1/4 )	
No load speed : min.-1 = rpm.		10,000 9,000 for USA, Brazil, Switzerland	4,000 - 10,000 4,000 - 9,000 for USA, Brazil, Switzerland
Safety clutch		Yes (SJS system)	
Electronic	Current limiter	Yes	Yes
	Pre-setting dial for speed control	No	Yes
	Soft starter	Yes	Yes
	Constant speed	Yes	Yes
Cord length : m ( ft )		2.5 ( 8.2 )	
* Net weight : kg ( lbs )		2.4 ( 5.3 )	

\* Net weight : without wheel and grip

## ► Standard equipment

- \* Lock nut wrench ..... 1 pc.
- \* Depressed center wheel 150 - 36 ..... 1 pc.
- \* Grip 36 ..... 1 pc.

< Note > The standard equipment for the tool shown may differ from country to country.

## ► Optional accessories

- \* Depressed center wheel 150 - 24
- \* Depressed center wheel 150 - 36
- \* Abrasive disc 150 - 24
- \* Abrasive disc 150 - 30
- \* Abrasive disc 150 - 50
- \* Abrasive disc 150 - 80
- \* Abrasive disc 150 - 120
- \* Rubber pad
- \* Lock nut 16 - 48
- \* Wire cup brush 90
- \* Super flange 47 (only for DIN type spindle thread)
- \* Diamond wheel 150
- \* Head cover

## < 1 > Lubrication

Apply MAKITA grease SG. No.0 to the following portions marked with black triangle to protect parts and product from unusual abrasion.

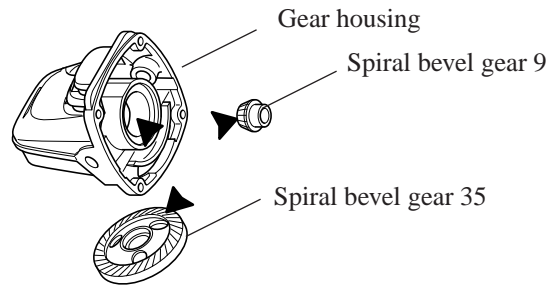

## < 2 > Disassembling spiral bevel gear 9 and armature

- (1) Remove tapping screw 4x18 and separate rear cover from motor housing.  
And remove carbon brush as illustrated in Fig. 1.
- (2) Remove tapping screw 4x28 and detach gear housing from motor housing.  
And remove armature with gear housing cover as illustrated in Fig. 1.
- (3) Disassemble retaining ring S-6 and flat washer 6 from armature shaft as illustrated in Fig. 1A.
- (4) Grip spiral bevel gear 9 with your gloved hand, and pull off spiral bevel gear 9 with turning anti-clockwise.  
Then, flat washer 12 and lock spring 12 can be separated from armature shaft together with spiral bevel gear 9 as illustrated in Fig. 1B.
- (5) Disassemble spiral bevel gear 9 with No. 1R269 "Bearing extractor" as illustrated in Fig. 1C, if it is difficult to disassemble with hand.

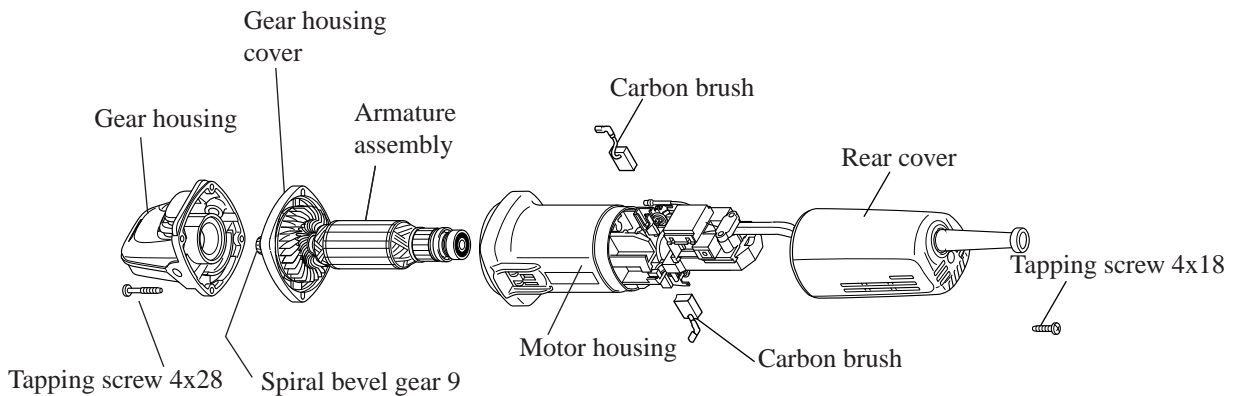

Fig. 1

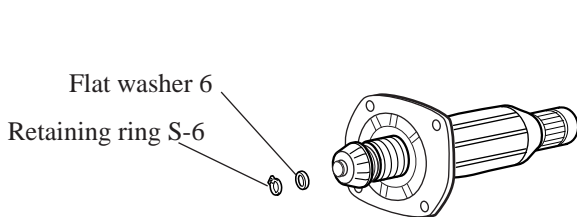

Fig. 1A

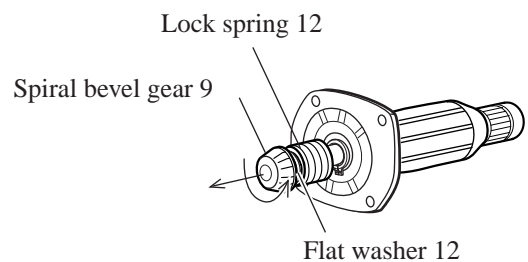

Fig. 1B

1R269 Bearing extractor

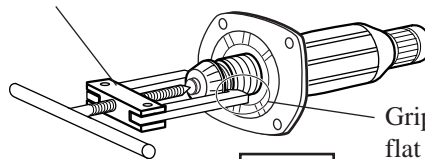

Fig. 1C

Gripping spiral bevel gear 9 together with flat washer 12, disassemble them from armature shaft.

- (6) Take off retaining ring S-12 from armature shaft as illustrated in Fig. 1D. And disassemble armature from gear housing cover with No. 1R045 "Gear extractor (large)" as illustrated in Fig. 1E.

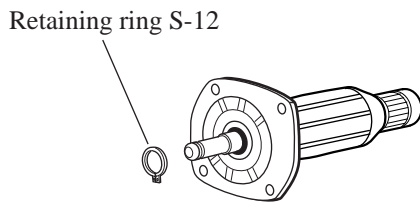

Fig. 1D

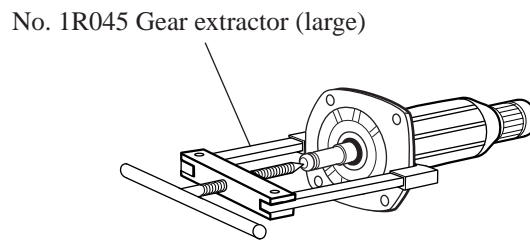

Fig. 1E

< 3 > Assembling spiral bevel gear 9 and armature

- (1) Put gear housing over on No. 1R217 "ring 22", and assemble armature to gear housing cover by pressing with arbor press as illustrated in Fig 2.
- (2) Assemble retaining ring S-12 to armature shaft. And then, assemble lock spring 12 and flat washer 12 to armature shaft as illustrated In Fig. 2A.
- (3) Assemble spiral bevel gear 9 to armature shaft with turning clock wise as illustrated in Fig. 2B.
- (4) Assemble flat washer 6. And then, fix the parts on armature shaft with retaining ring S-6 as illustrated in fig. 2C.

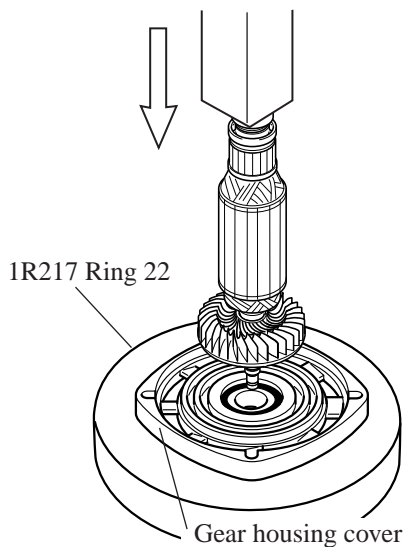

Fig. 2

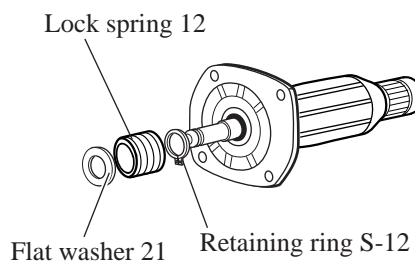

Fig. 2A

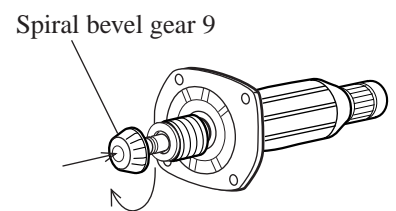

Fig. 2B

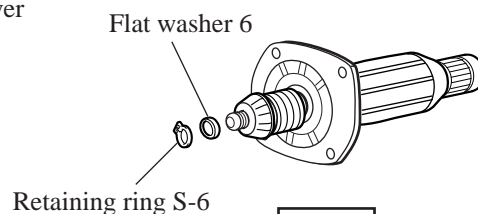

Fig. 2C

< Note in assembling >

**When replacing spiral bevel gear 9 with new one, also retaining ring S-6 and flat washer 6 have to be replaced with new ones.**

## ► Repair

### < 4 > Disassembling gear section

- (1) Separate gear section by unscrewing 4 pcs. of hex socket head bolts M4 x 16 as illustrated in Fig 3.  
**It is recommended to unscrew hex socket head bolts M4 x 16 with impact driver, because they are adhesive bolts.**
- (2) Put gear section on No.1R217 "Ring 22". And disassemble spindle from spiral bevel gear 35 by pressing with arbor press as illustrate in Fig. 3A.
- (3) Disassemble bearing retainer by turning anti-clockwise as illustrate in Fig. 3B.

< Note >

For disassembling bearing retainer, remodel No.1R043 "Wrench for bearing retainer" by expanding the distance between the spikes from 20mm to 21 or 22mm as illustrated in Fig. 3C.

- (4) Disassemble ball bearing 6201DDW by slightly hitting the edge of bearing box with plastic hammer as illustrate in Fig. 3D.

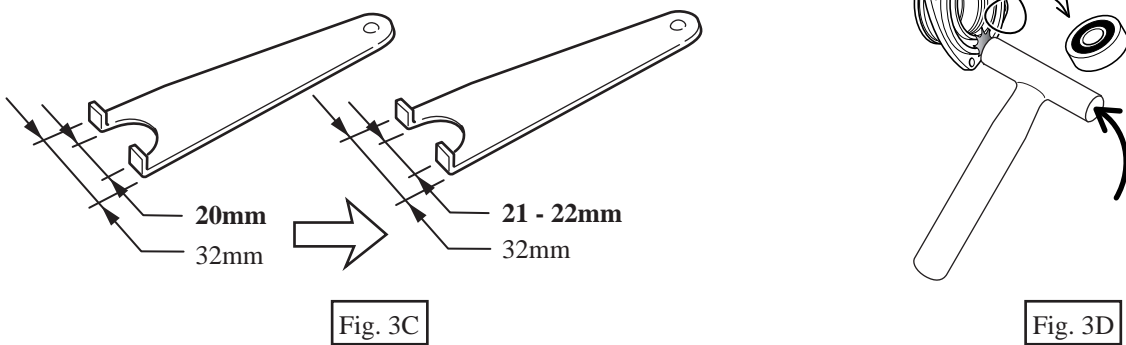
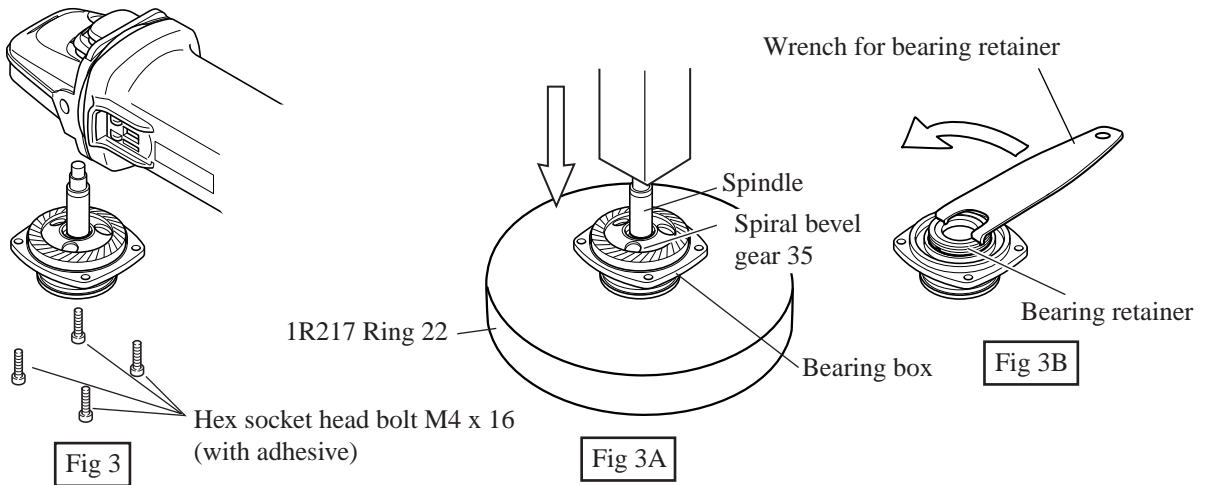

### < 5 > Assembling gear section

- (1) Assemble ball bearing 6201DDW to bearing box by pressing with arbor press as illustrated in Fig. 4.
- (2) Assemble bearing retainer to bearing box by turning clockwise as illustrated in Fig. 4A.

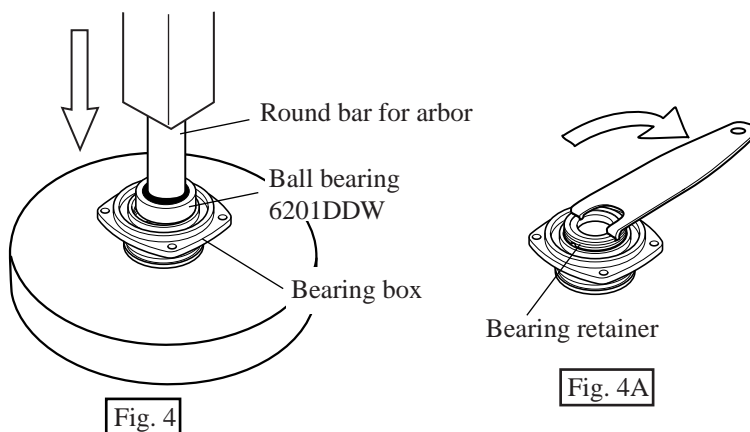

- (4) Supporting spiral bevel gear 35 with 1R028 "Bearing setting pipe", assemble spindle to spiral bevel gear 35 by pressing with arbor press as illustrated in Fig. 4B.
- (5) Assemble the gear section to gear housing by fastening with 4 pcs. of hex socket head bolts M4 x 16 as illustrated in Fig. 4C.

< Note in assembling >

**The hex socket head bolts M4 x 16 are adhesive ones. The used hex socket head bolts have to be replaced with fresh ones.**

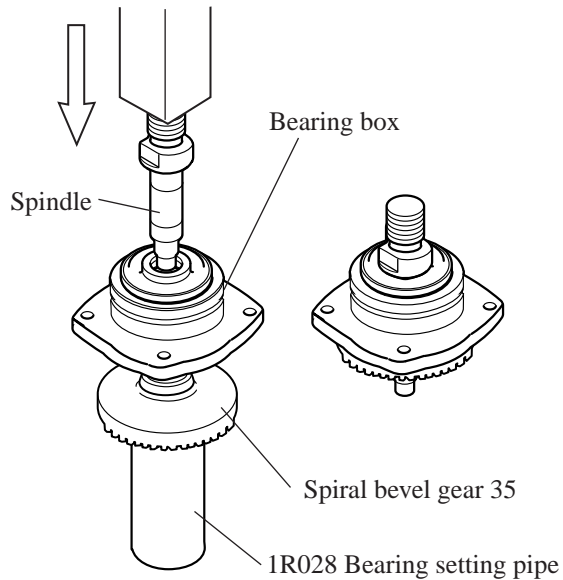

Fig. 4B

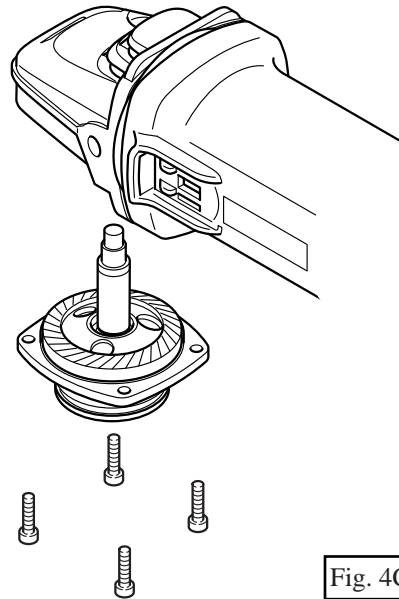

Fig. 4C

< 6 > Attaching carbon brush

Connect the receptacle of carbon brush with the terminal of brush holder by pushing in the direction of the arrow, as illustrated in Fig. 5.

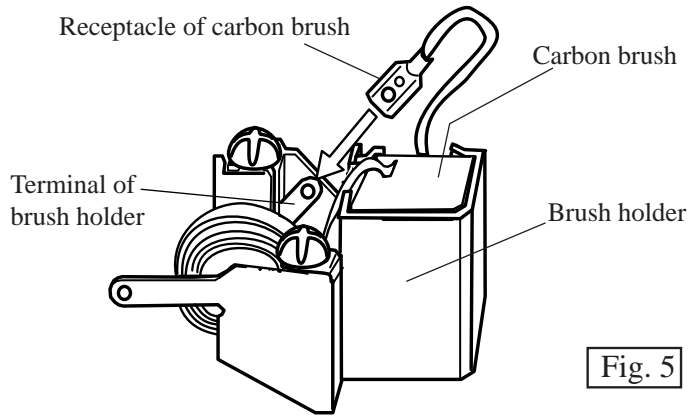

Fig. 5

Push the receptacle of carbon brush until it stops as illustrated in Fig. 4A.

Completely attached receptacle of carbon brush

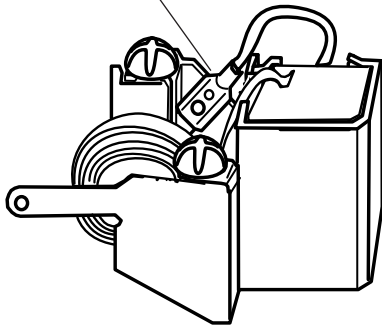

Fig. 5A

Incompletely attached receptacle of carbon brush

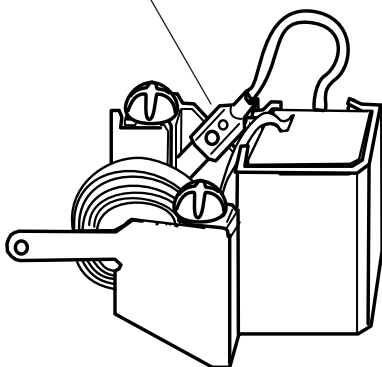
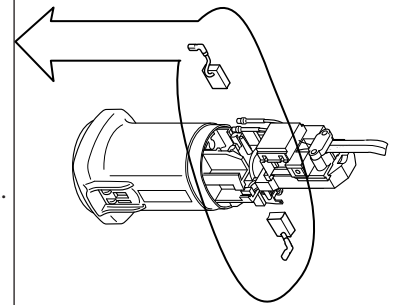



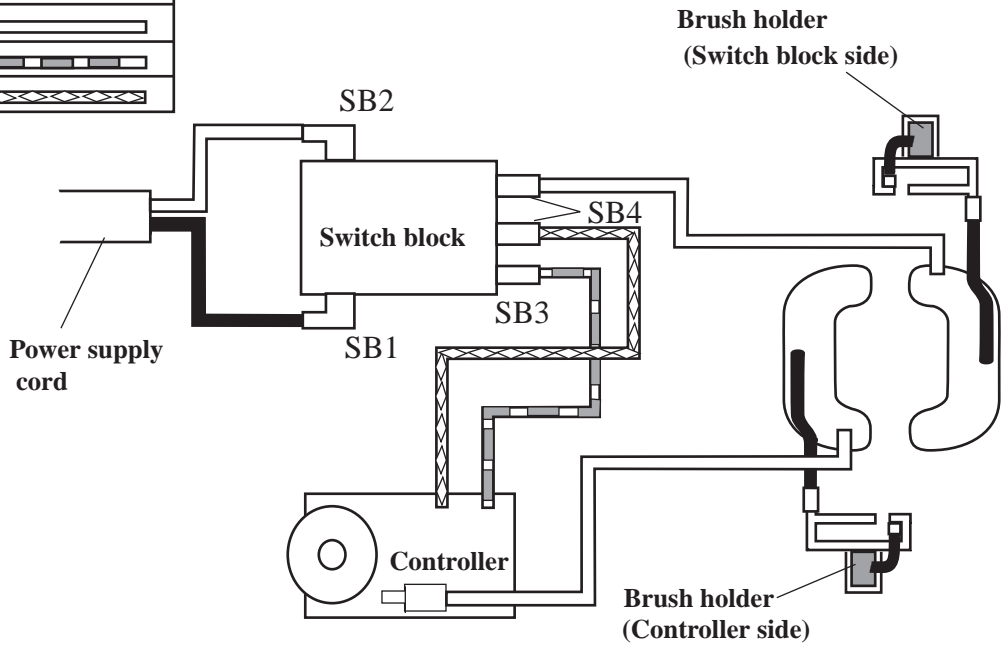

Fig. 5B



▶ **Circuit diagram**

Color index of lead wires	
Black	
White	
Red	
Blue	



▶ **Wiring diagram**

Model 9566C,CV

with electronic features

Model 9566C : without speed control dial

Model 9566CV : with speed control dial

Put the lead wires of controller in the lead holder so that they are not slacken.

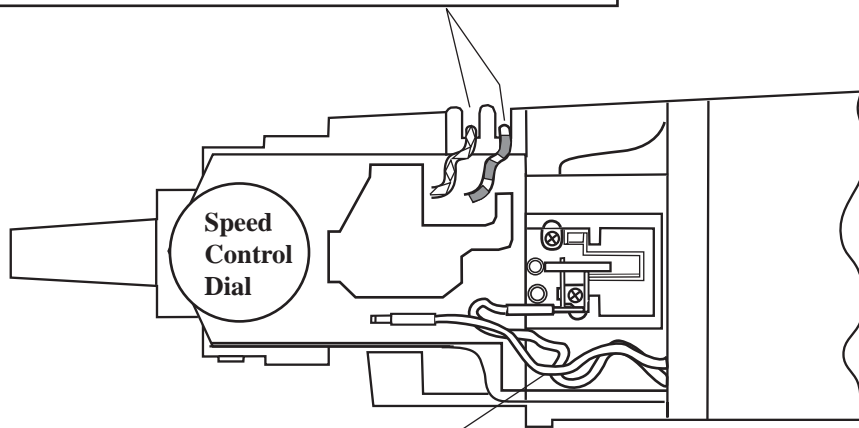

Be careful not to loosen the lead wires of field in motor housing. Put the loosened lead wires in the above place.

Model 9566C,CV

with electronic features

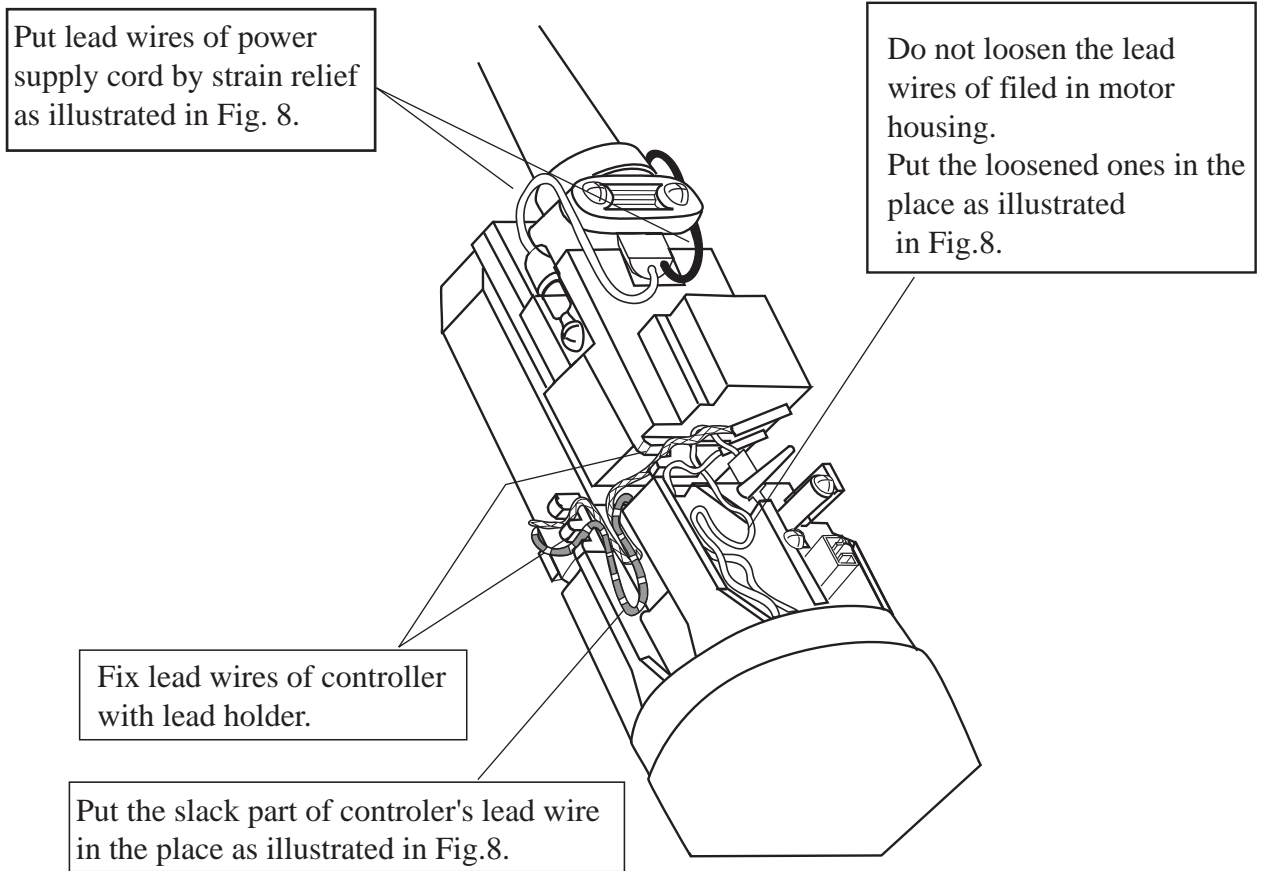

Fig. 8