

T ECHNICAL INFORMATION

Makita

New Tool

Models No. ▶ 9741

Description ▶ Makita wheel type sanding machine

CONCEPTION AND MAIN APPLICATIONS

The product is the multi-purpose sanding machine which can efficiently conduct the wood grain texture revealing, rust or paint removing, and polishing processes by using various wheels.

The model 9740 is supplied with a nylon brush wheel 120-100 and a wooden box. The model 9741 is supplied with a slitted paper wheel 120-40 and steel box.

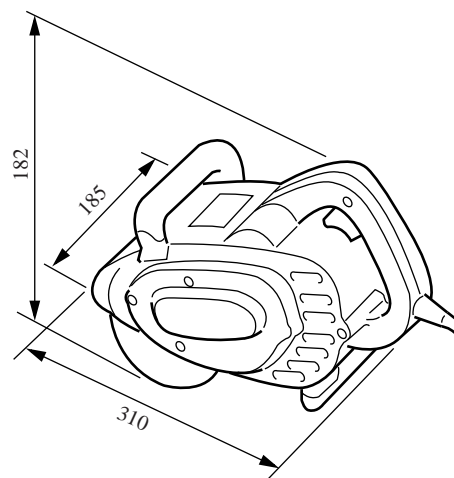

▶ Specifications

Voltage(V)	Current(A)	Frequency(Hz)	Continuous rating input(W)	Rated output(W)	Max. output(W)
100	11	50-60	1050	600	830
115	7.8	50-60	860	480	830
200	4.5	50-60	860	480	830
220	4.1	50-60	860	480	830
230	3.9	50-60	860	480	830
240	3.8	50-60	860	480	830

No load speed(/min.)	3,500/min
Wheel dimension	100mm x 120mm
Useable wheel dimension	70 to 100 mm in diameter and 120 mm in thickness Rollers are installed in front and the rear of the roller and the front roller is adjustable in the vertical direction.
Weight(kg)	4.2kg
Cord length(m)	5m

▶ Standard equipment

- Joint (to connect a dust collector)
- Hex. wrench 6 --- 2 pieces (to mount and dismount wheels.)

▶ Optional accessories

- Nylon brush wheel 120-100 (for grain texture revealing, rough finishing, and rust removing processes)
- Nylon brush wheel 120-240 (For grain texture revealing process)
- Wire brush wheel 120 (for removing rust)
- Slitted paper wheel 120-40 (For removing rust and paint)
- Cotton buff wheel 120 (for polishing)

The standard equipment for the tools shown may differ form country to country

► Repair

1. Replacement of the armature

Disassembling sequence

- (1) Dismantle the wheel.
- (2) Remove the grip and carbon brush.
- (3) Remove the pan head setting screws from 1 to 5 shown in the fig. on the right, gear housing and then housing to dismantle the armature.

