

T ECHNICAL INFORMATION



New Tool

Models No. ▶ 9900B

Description ▶ Belt Sander Stand

CONCEPTION AND MAIN APPLICATIONS

This is the belt type sanding stand made up of a base and a guide rail for easily sanding small parts or deburring. This is offered as the special accessory for the 9900B, 9924B, 9924DB and M991 models.

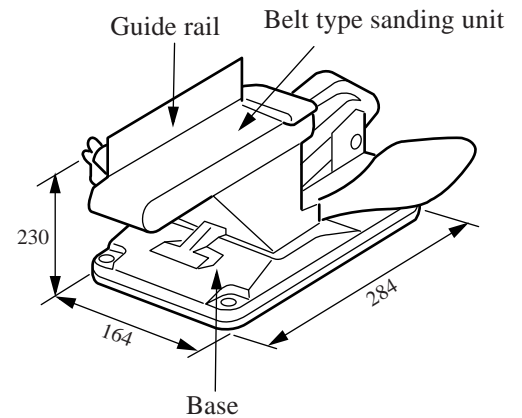

▶ Specifications

| | |
|---|-------------------------------------|
| Guide rail dimension | 56 x 210 mm |
| Adjustable angle of the guide rail | 45 to 90 to the belt surface |
| Grinding width | (Same as that of the sanding belt.) |
| Weight(kg) | |