

# T ECHNICAL INFORMATION

**Models No.** ▶ 9902, 9903, 9920, 9404

**Description** ▶ Belt Sander

## CONCEPTION AND MAIN APPLICATIONS

Belt size for Model 9902, 9903 : 76mm x 533mm (3" x 21")  
 Belt size for Model 9920 : 76mm x 610mm (3" x 24")  
 Belt size for Model 9404 : 100mm x 610mm (4" x 24")  
 Model 9903, 9920 and 9404 are equipped with Speed Adjusting Dial for getting optimum belt speed to suit various work piece. And all of the above models are equipped with auto tracking belt system.

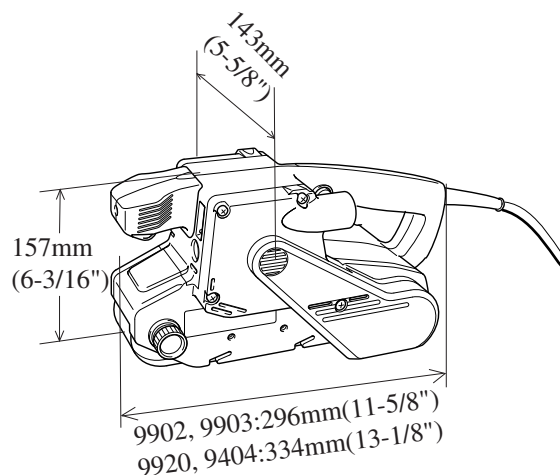

## ► Specifications

The following electrical data are common to Model 9902, 9903, 9920 and 9404.

Voltage (V)	Current (A)	Cycle (Hz)	Continuous Rating (W)		Max. Output(W)
			Input	Output	
100	11	50 - 60 Hz	1,050	450	850
110	9.7	50 - 60 Hz	1,010	450	850
120	8.8	50 - 60 Hz	1,010	450	850
220	4.8	50 - 60 Hz	1,010	450	1,000
230	4.6	50 - 60 Hz	1,010	450	1,000
240	4.4	50 - 60 Hz	1,010	450	1,000

Model No.	9902	9903	9920	9404
Belt speed	7.3 m/s	3.5m/s - 7.3 m/s		
Belt size	76mm x 533mm (3" x 21")	76mm x 610mm (3" x 24")	100mm x 610mm (4" x 24")	
Cord length	4m for European countries		5 m (16.4 ft) for other than Europe	

## ► Standard equipment

Abrasive belt AA80  
 Dust bag

The standard equipment shown may differ from country to country.

## ► Optional accessories

Abrasive belt AA40, 60, 80, 100, 120, 150, 180, 240  
 Abrasive belt CC40, 60, 80, 100, 120, 150, 180, 240  
 Stand  
 Sanding shoe  
 Hose 28

## ► Repair

### < 1 > Replacing helical gear 39 complete

- (1) Take off abrasive belt. Remove safety cover by loosening tapping screw CT4 x 16 (2pcs.), and belt cover by loosening the same CT4 x 16.
- (2) Take off synchro belt 6-330. Remove gear cover by loosening tapping screw CT4 x 16 (4 pcs.).
- (3) Insert hex wrench 2.5 into the punched hole on helical gear 39 complete to lock driving roller.
- (4) Remove driving roller with box wrench 19 turning it clockwise in stead of anti-clockwise.

Then, helical gear 39 complete can be separated from driving roller easily.

( Helical gear 39 complete can be removed in the above mentioned way easily, because ball bearing and gear shaft are assembled to riving roller, however, without pressing.)

- (5) Take the reverse steps for assembling helical gear 39 complete using the following repairing tools .
  - \* No.1R219 Torque wrench (Adjust the fastening torque 6.0 - 8.5 N.m in advance for these models.)
  - \* No.1R220 Ratchet head
  - \* No.1R222 Socket adaptor

Do not forget to apply Makita grease No.2 (4 g) for lubrication on helical gear 39.

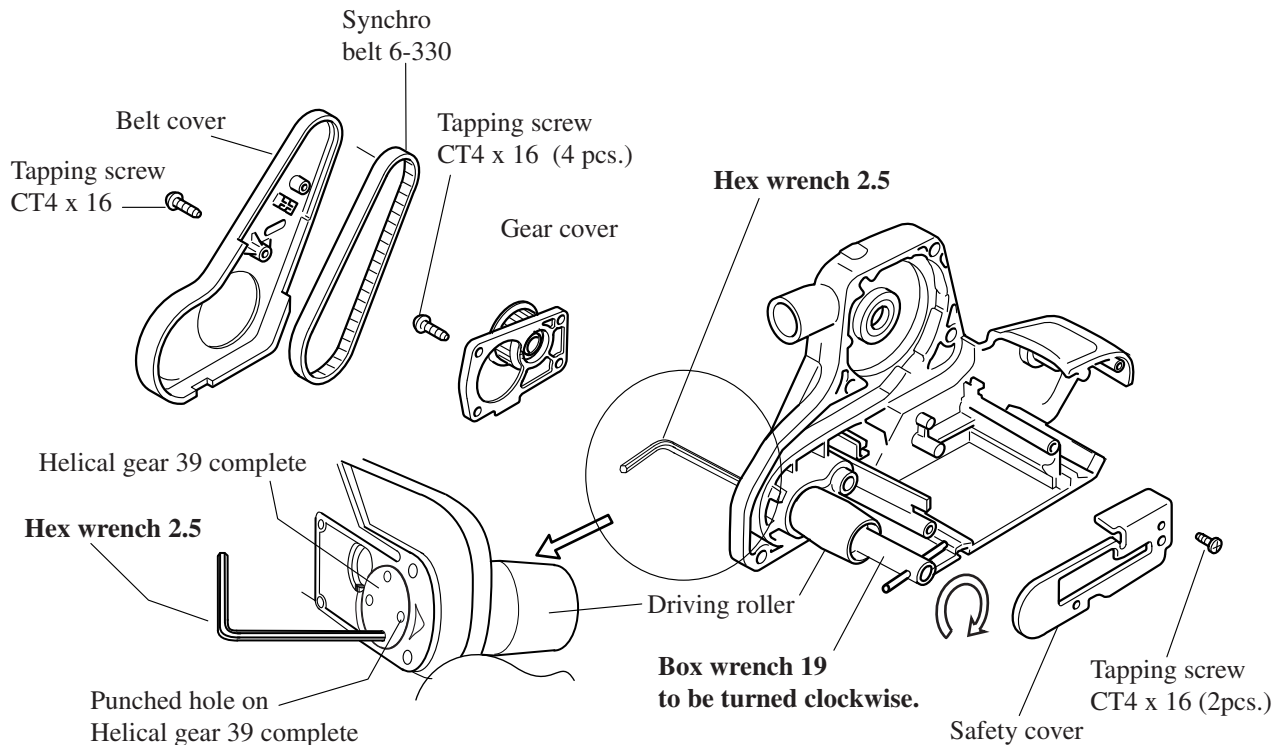

### < 2 > Replacing helical gear 10

- (1) Hold helical gear 10 with the following repairing tools.
  - \* 1R041 Copper plate
  - \* 1R082 Vise
- (2) Remove pulley 9.5-46.0 with box wrench 19 by turning it anti-clockwise.
- (3) Take reverse steps for assembling helical gear 10 using the following repairing tools.
  - \* No.1R219 Torque wrench (Adjust the fastening torque 6.0 - 8.5 N.m in advance for these models.)
  - \* No.1R220 Ratchet head
  - \* No.1R222 Socket adaptor

**Be careful not to damage the new helical gear 10 with vise, when assembling.**

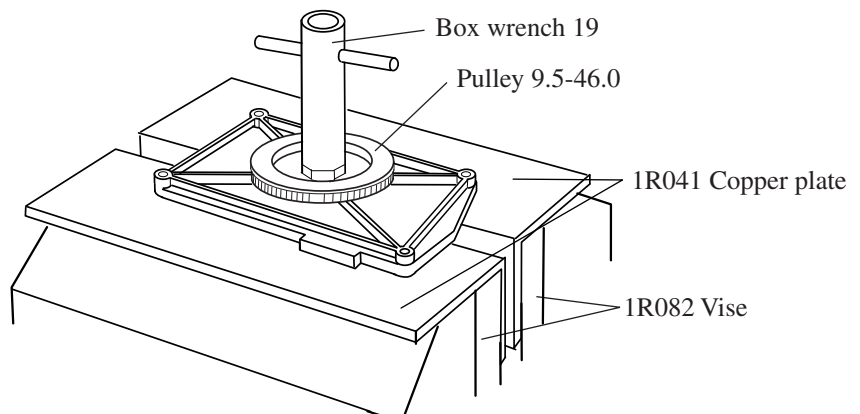

### < 3 > Replacing armature

- (1) Remove belt cover by loosening tapping screw CT4 x 16 (1 pc.). Take off synchro belt 6-330.
- (2) Separate frame complete from motor housing by loosening tapping screw 4 x 30 (5 pcs.) and the same CT4 x 16 (1 pc.).
- (3) Remove motor cover from motor housing by loosening tapping screw 4 x 18 (4pcs.).
- (4) Take off carbon brush.
- (5) Remove fan 76 and hex nut M6 by turning them clockwise from armature. And remove armature from motor housing.
- (6) Take the reverse steps for assembling armature. (It is enough that fan 76 can be slightly fastened with hand .)

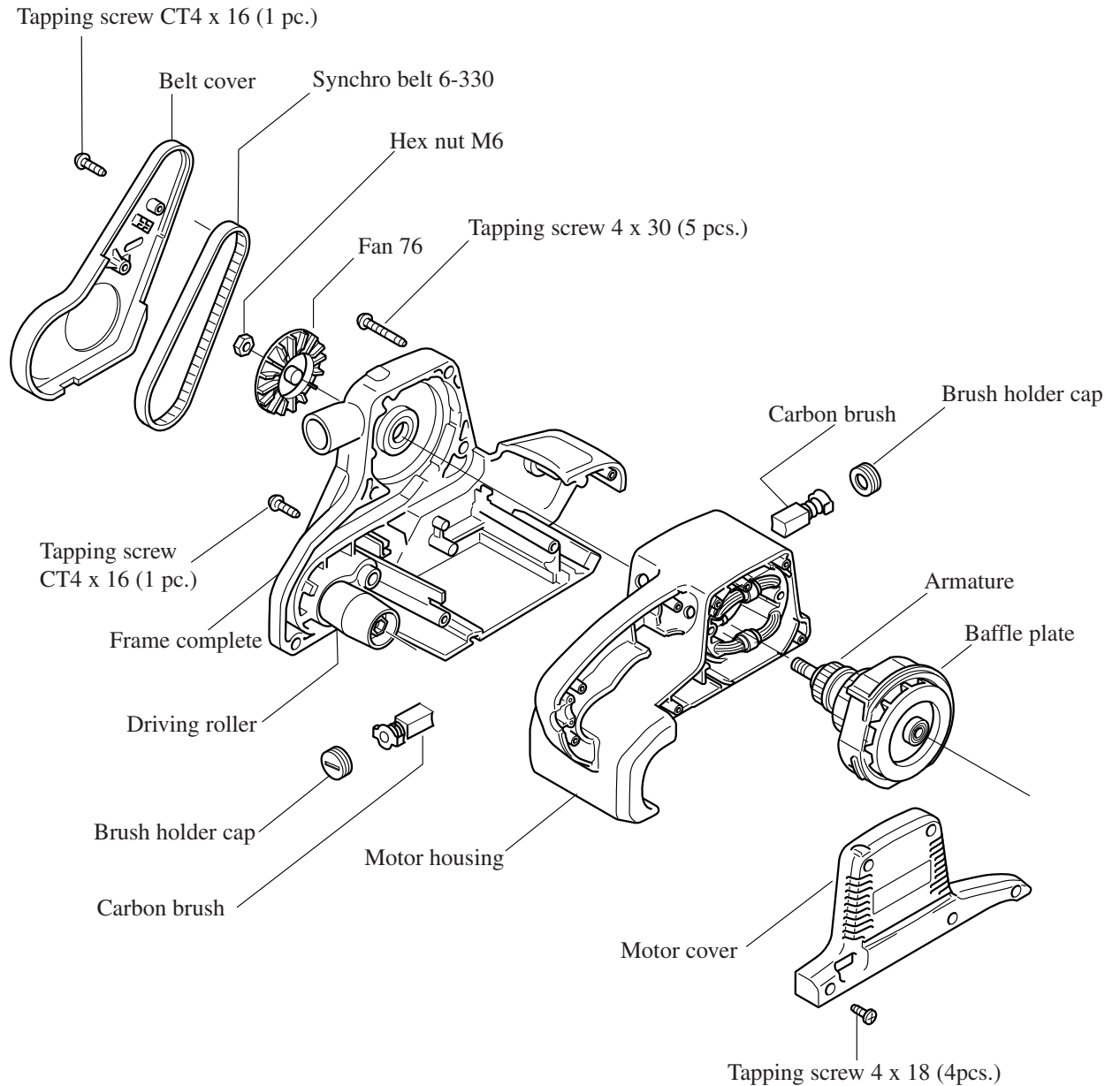

## ▶ Circuit diagram

Model 9903, 9920 and 9404 (equipped with controller)

< Note > Noise suppressor is not used in some country.

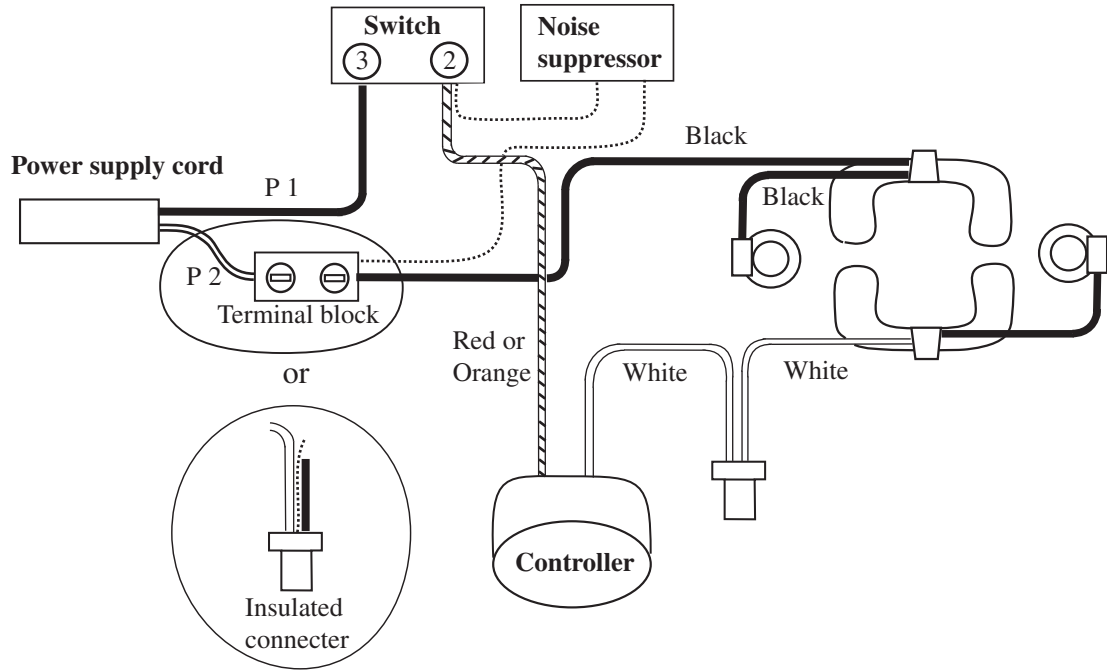

Model 9902 (without controller)

< Note > Noise suppressor is not used in some country.

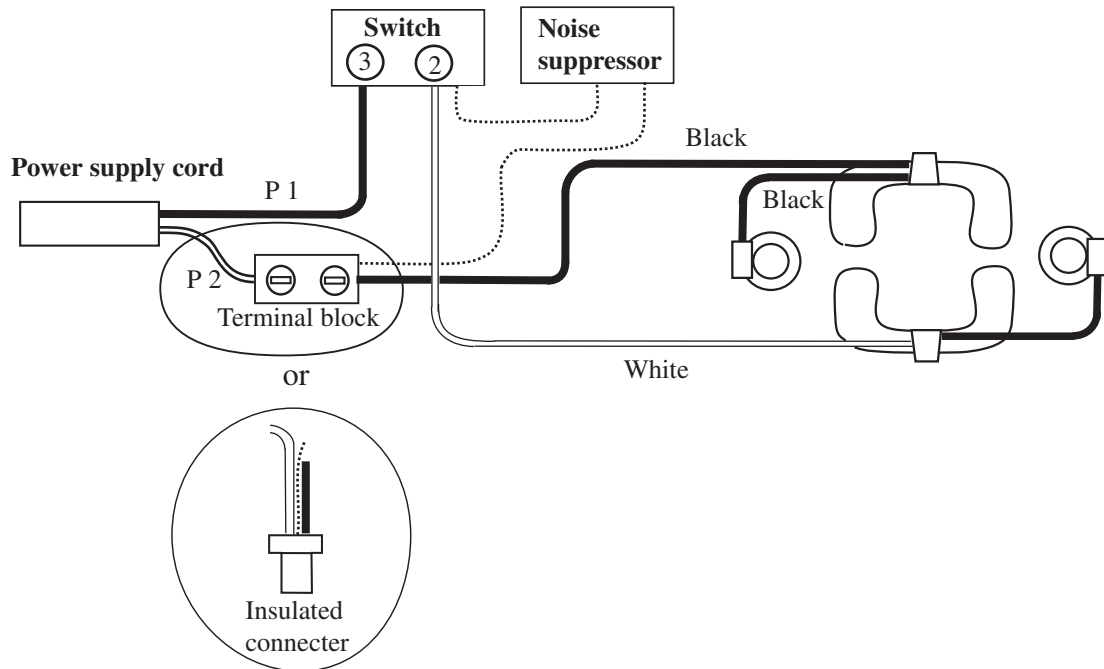

# Wiring

Model 9903, 9920 and 9404 (equipped with controller)

(View from motor cover side)

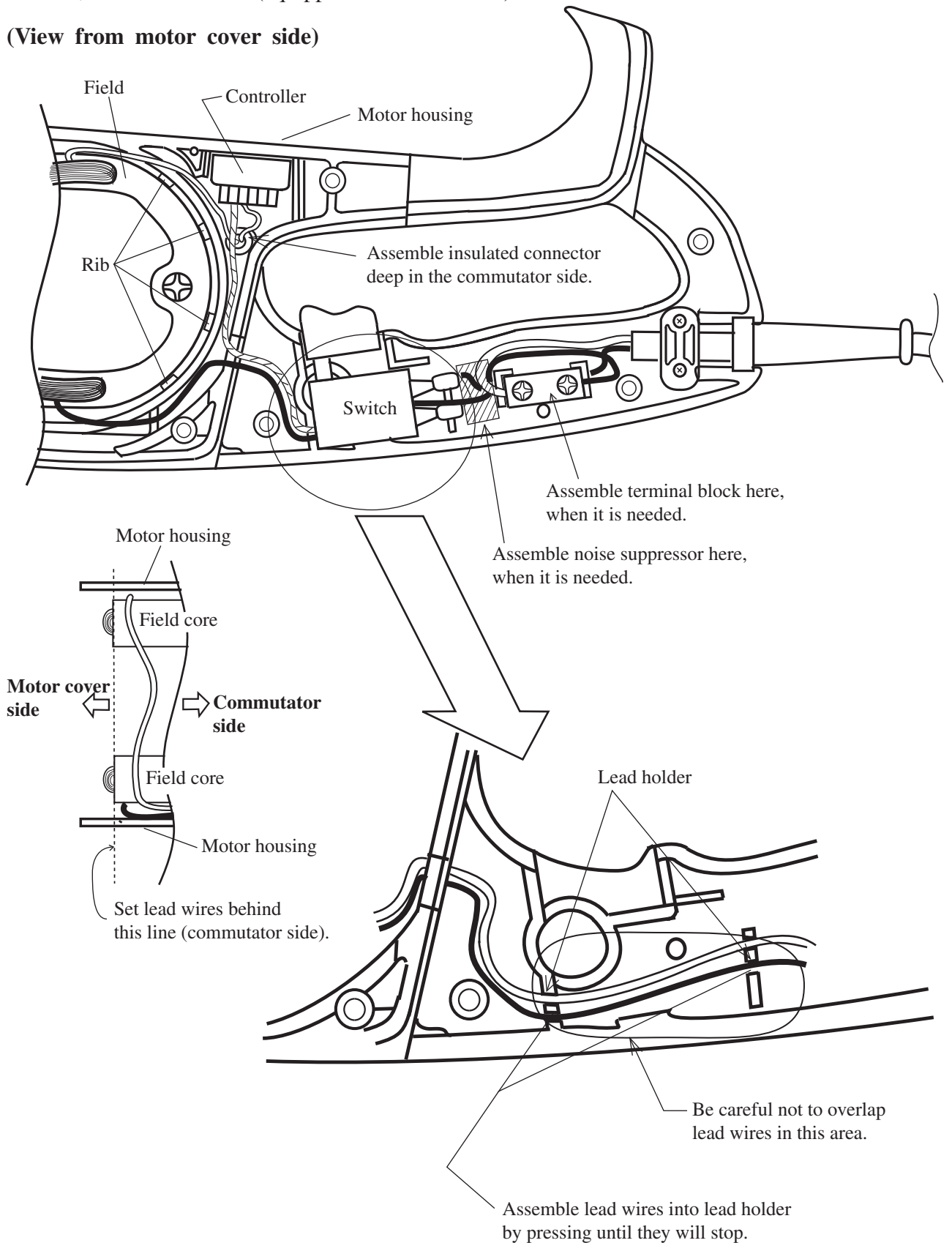

# Wiring

Model 9902(without controller)

(View from motor cover side)

