

T ECHNICAL INFORMATION



New Tool

Models No. ▶ 9910

Description ▶ 76mm Belt Sander

CONCEPTION AND MAIN APPLICATIONS

Model 9910/9911 are new compact belt sanders using 76mm x 457mm(3"x18") abrasive belt. Their brief benefits are; Highest capacity at sanding and dust-collection among the same class sanders.

*Variable speed control by dial for operator's needs (Model 9911 only)

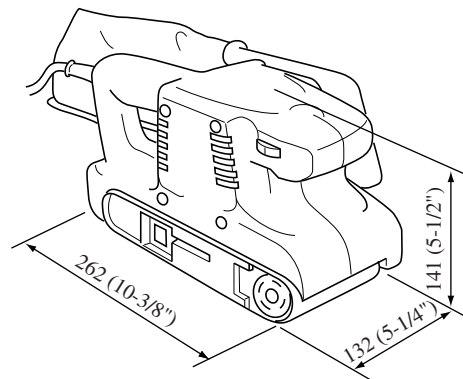

► Specifications

Voltage (V)	Current (A)	Cycle (Hz)	Continuous Rating (W)		Max. Output(W)
			Input	Output	
100	6.8	50/60	650	200	640
120	5.6	50/60	650	200	640
220	3.0	50/60	650	200	640
230	3.0	50/60	650	200	640
240	2.9	50/60	650	200	640

Belt speed	9910	270m/min (900ft/min)
	9911	75-270m/min (250-900ft/min)
Belt size	76mm(3") x 457mm(18")	
Net weight	2.6Kg(5.7lbs)	
Cord length	2.5m(8.2ft)	

► Standard equipment

- Dust Bag -----1 pc.
 - Abrasive Belt AA80-----1 pc. (Model 9910)
 - Abrasive Belt AA60, 100,150 -----1 pc. (Model 9911)
- <Note> The standard equipment may differ from country to country.

► Optional accessories

- Abrasive Belt AA40, 60,80, 100,150,180,240
- Clamp Complete
- Hose Complete 28-1.5
- Hose Complete 28-3.0

The standard equipment for the tools shown may differ from country to country.

► Repair

(1) Replacing of armature

- 1) Loosen the tapping screw PT4 x25 for mounting the housing R to remove the housing R, and the fan 60 for cooling the motor will be exposed.
- 2) Loosen the tapping screw PT4 x25 for mounting the belt cover to remove the belt cover.
- 3) Disconnect the holder cap and then remove the carbon brush.
- 4) Remove the synchro belt 6-300 and steel plate.

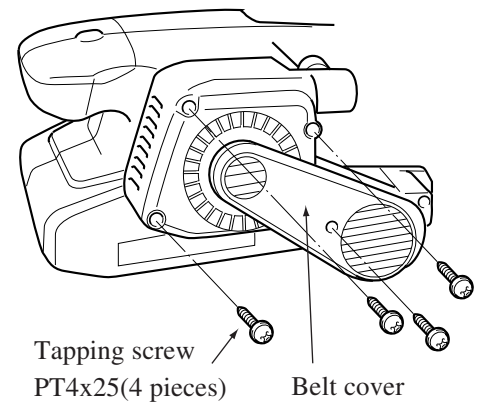
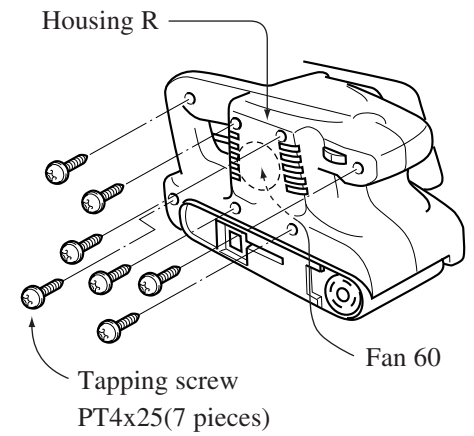

- 5) Turn the fan 68 in clock wise direction to remove it while fixing the fan 60 for cooling the motor.
(Note) Since the fan 68 is mounted with anti-clock wise screw, turn in clock wise to remove.

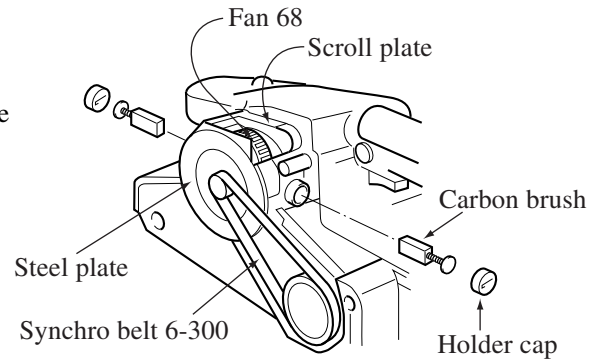

- 6) Remove the scroll plate.

- 7) Use the resin hammer to slightly hammer the armature shaft from the commutator side to disconnect the armature.

(2) Disassembling of gear

- 1) In the same manner as replacing of armature, remove the housing R, belt cover and synchro belt 6-300.

- 2) Remove the shoe, and the driving roller will be exposed.

- 3) Use the spanner 10 to fix the hexagon point of pulley 8.5-45.1 and turn the driving roller in the direction whereby anti-clock wise screw can be loosened, and either of the pulley 8.5-45.1 or driving roller is loosened and then removed.

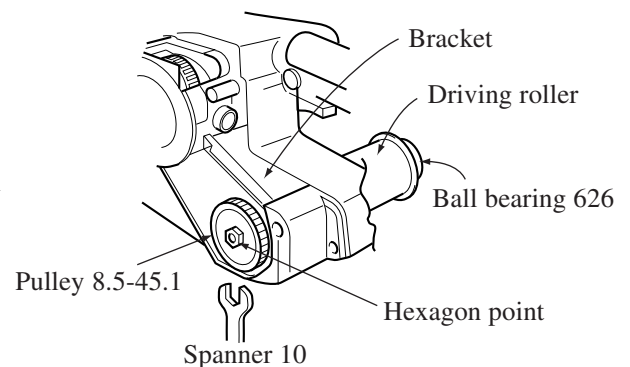

- 4-A) If the pulley 8.5-45.1 has been successfully removed,
 - A-a) Loosen the 4 pieces of tapping screw PT4x25 for mounting the bracket to remove the bracket.

- A-b) Insert the lock nut wrench 20 through the two holes on the helical gear 31, fix the helical gear 31, and then turn the driving roller in a direction whereby the left-handed screw can be loosened.

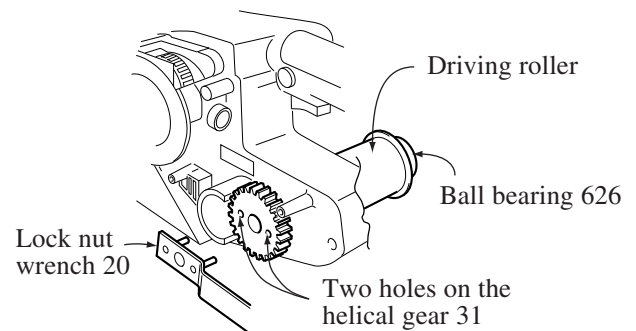

- A-c) If the ball bearing 626 and driving roller have been successfully removed, use the resin hammer to slightly hammer the helical gear 31 complete from the direction of ball bearing 626 mounting side to remove the helical gear 31 complete.

- 4-B) If the driving roller has been loosened and successfully removed along with the ball bearing 626,

- B-a) Set the spanner 10 on the hexagon point of pulley 8.5-45.1, insert the spanner 7 in the two faces on driving shaft, and then turn them in the direction whereby the right-handed screw can be loosened, and the pulley 8.5-45.1 can be removed.

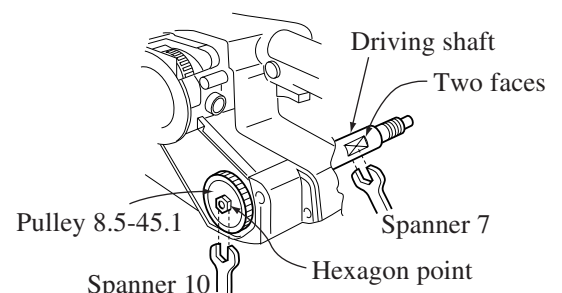

- B-b) Loosen the 4 pieces of tapping screw PT4x25 for mounting the bracket to remove the bracket.

- B-c) Use the resin hammer to slightly hammer the helical gear 31 complete from the direction of ball bearing 626 mounting side to remove the helical gear 31 complete.

(3) Assembling of the rubber sleeve 29

- 1) Insert the rubber sleeve 29 into the outer circumference of the driving roller by hands as far as possible.
- 2) Push the rubber sleeve 29 and insert it while floating the rubber sleeve 29 by blowing the air into the clearance between rubber sleeve 29 and driving roller using the air gun.

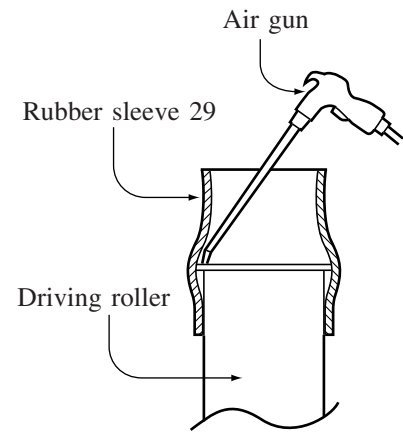

► Circuit drawing

M990

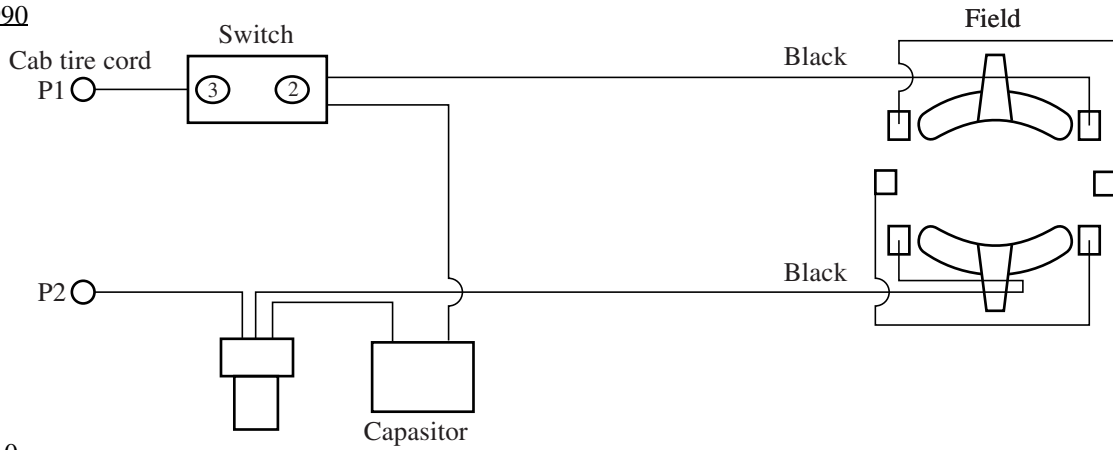

9910

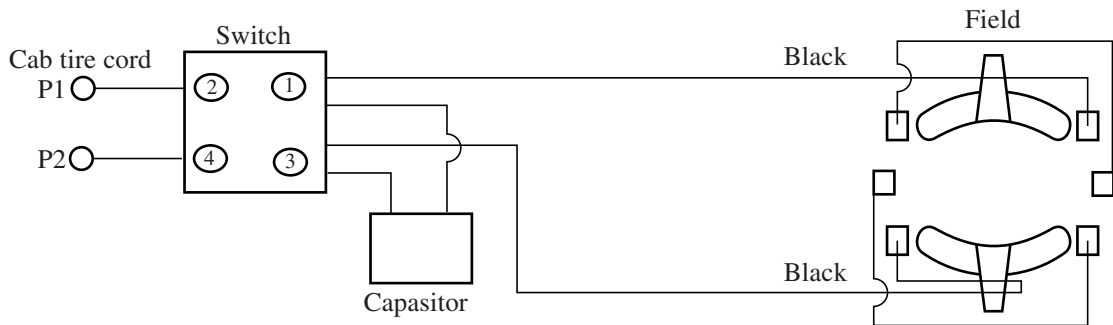

The condenser is not used in some areas.

9911

<100V area>

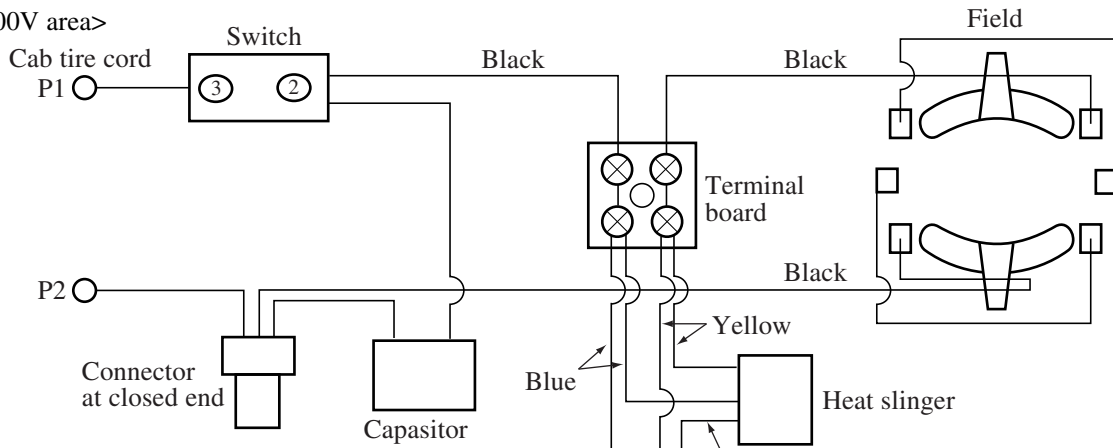

<Area for other than 100V>

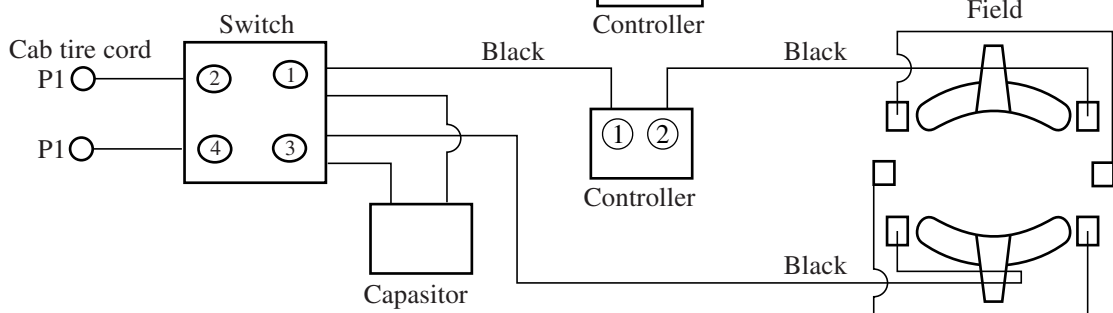

The condenser is not used in some areas.